



Geophysics and natural risks: instruments and principles of data analysis

- Sebastian Uhlemann (University of Bremen)

IR0000032 – ITINERIS, Italian Integrated Environmental Research Infrastructures System
(D.D. n. 130/2022 - CUP B53C22002150006) Funded by EU - Next Generation EU PNRR-
Mission 4 “Education and Research” - Component 2: “From research to business” - Investment
3.1: “Fund for the realisation of an integrated system of research and innovation infrastructures”



Who am I?

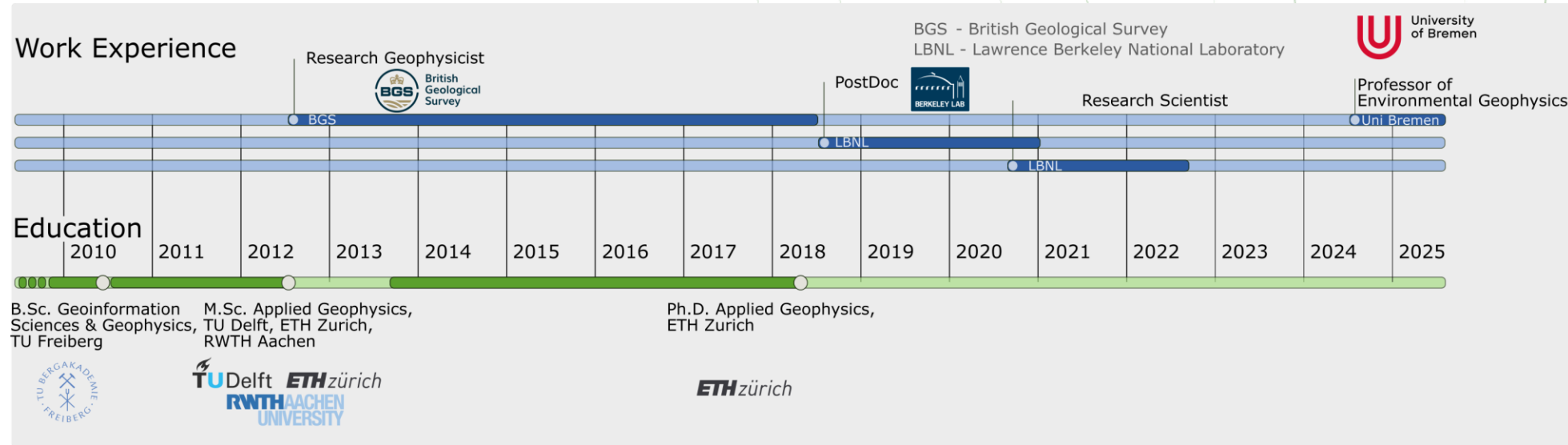

Research Focus: Hydrogeophysics

- **Integrated geoelectrical monitoring for water and energy applications**
- Development of **novel monitoring strategies** to address natural hazards
- **Optimization methodologies** to improve geophysical imaging

Applications:

- **Landslide investigations**
- **Hydrological processes – Groundwater studies**
- **Permafrost degradation**



Petrophysical relationships
linking geophysical and
hydrogeomechanical
parameters

IR0000032 – ITINERIS, Italian Integrated Environmental Research Infrastructures System
(D.D. n. 130/2022 - CUP B53C22002150006) Funded by EU - Next Generation EU PNRR-
Mission 4 “Education and Research” - Component 2: “From research to business” - Investment
3.1: “Fund for the realisation of an integrated system of research and innovation infrastructures”



Outline of the day

- **Fundamentals of electrical resistivity measurements**
 - Electrical properties of soils and rocks
 - Translating geoelectrical data into hydrogeomechanical properties
- **Principles of Electrical Resistivity Electromagnetic Measurements**
 - Applications on ground and airborne geophysical characterization
- **Geoelectrical monitoring: Principles and applications**
 - Inversion approaches, practical considerations
 - Monitoring applications
- **Machine Learning for exploiting and assimilating environmental data**

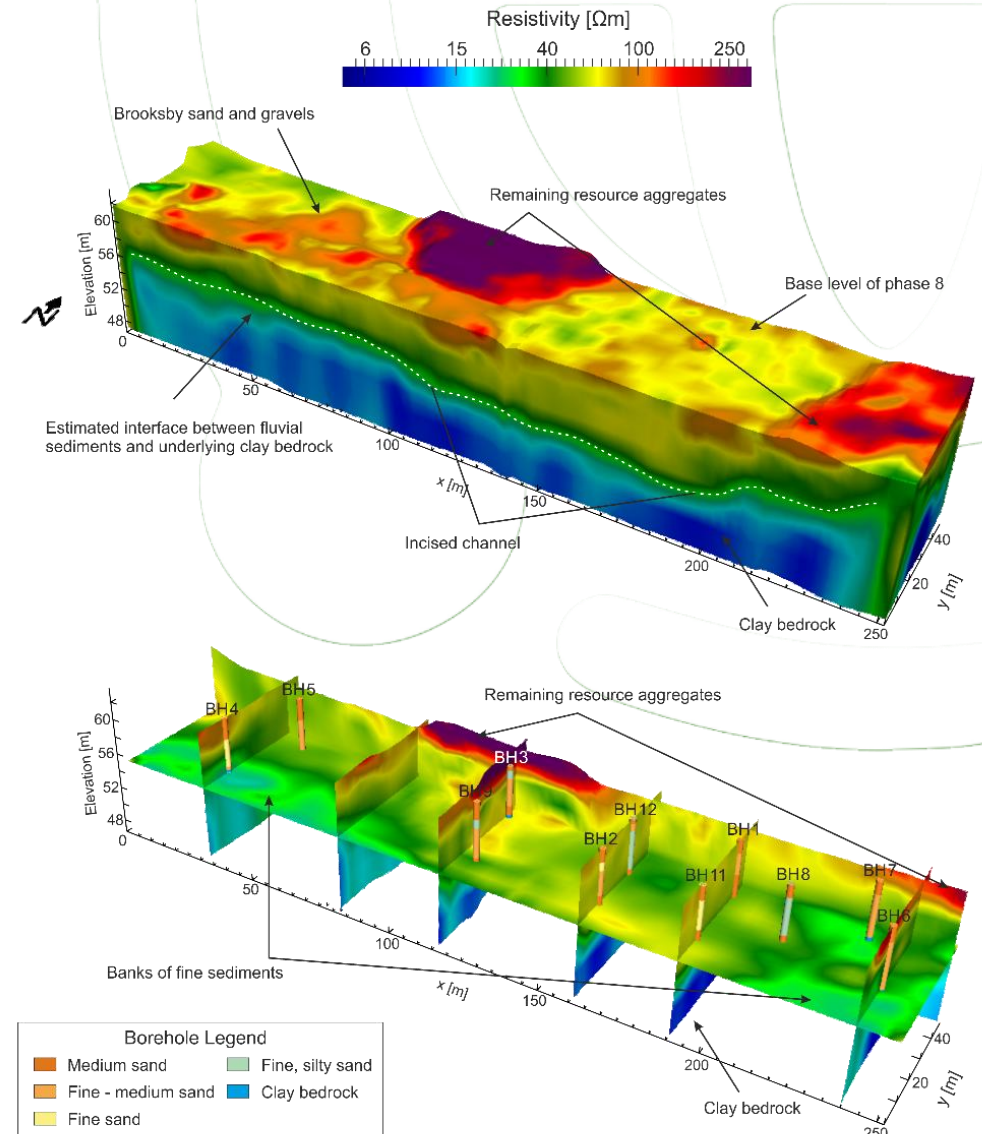

Why electrical and electromagnetic methods?

The electrical resistivity of Earth materials is highly sensitive to variations in the hydraulic properties of the subsurface:

- Porosity
- Saturation
- Grain size distribution (hydraulic conductivity)
- Pore fluid conductivity

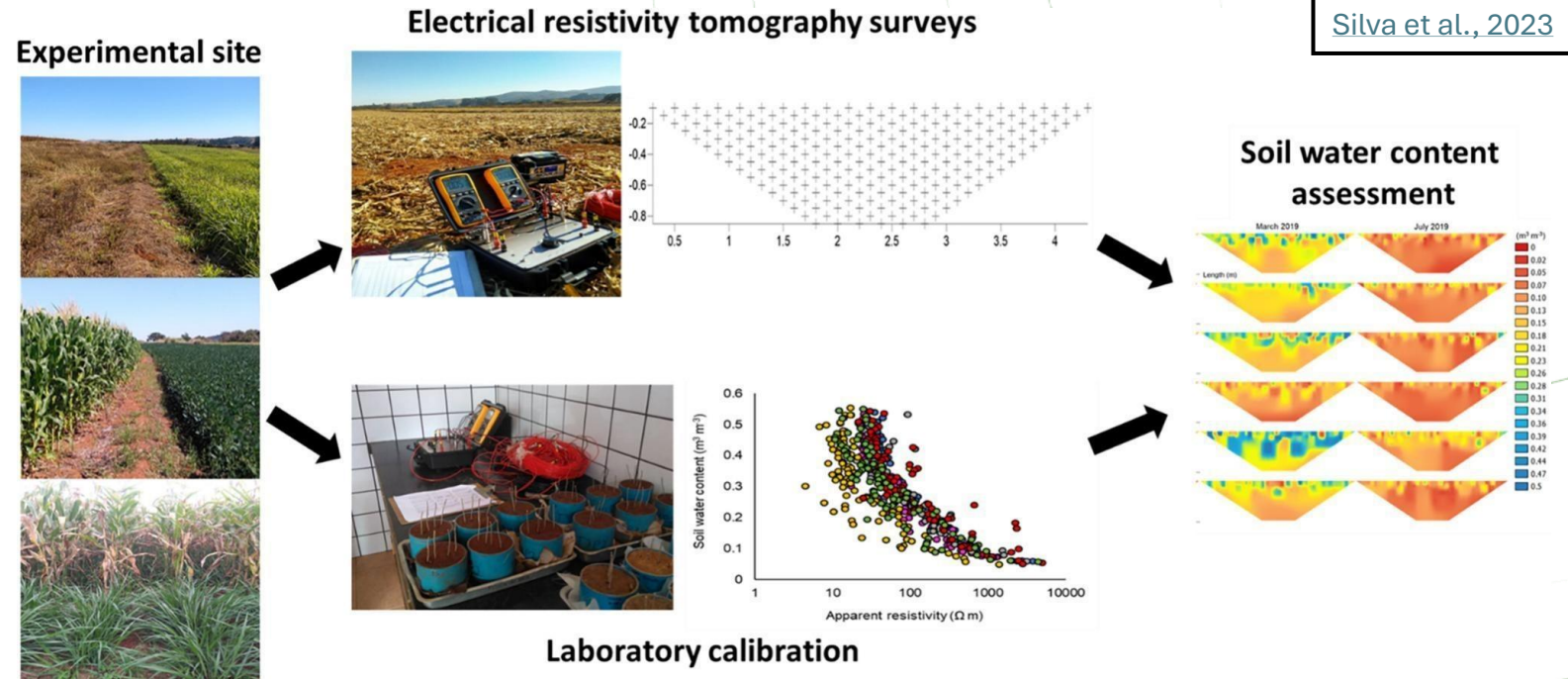

Wet, warm,
clay-rich, ion-rich
(salty)

Resistivity

Dry, cold,
no clay, ion-depleted

Electrical and electromagnetic methods

Different methods to measure the electro(magnetic) properties

4 different types of measurements to measure electrical and electromagnetic properties of Earth materials:

Geoelectrics: Changes in electrical resistance or conductivity (the reciprocal of resistivity) are measured by generating an electric current that flows through the soil using connected electrodes.

Electromagnetics (EM) respond to almost the same targets as geoelectrics, but they use time-varying electromagnetic fields rather than electrodes in the ground. This enables, for example, use from the air.

Magnetotellurics (MT) uses naturally induced currents (e.g. thunderstorms) whose propagation is measured by EM and resistance methods. This means that the results go much deeper than EM and geoelectrics.

Ground Penetrating Radar (GPR) records radar waves - a type of electromagnetic wave - that are reflected from surfaces and provide a more direct picture of the subsurface - similar to reflection seismology. However, it is usually limited to the uppermost meters of the ground.

Airborne EM survey



Electrical and electromagnetic methods

Different methods to measure the electro(magnetic) properties

4 different types of measurements to measure electrical and electromagnetic properties of Earth materials:

Geoelectrics: Changes in electrical resistance or conductivity (the reciprocal of resistivity) are measured by generating an electric current that flows through the soil using connected electrodes.

Electromagnetics (EM) respond to almost the same targets as geoelectrics, but they use time-varying electromagnetic fields rather than electrodes in the ground. This enables, for example, use from the air.

Magnetotellurics (MT) uses naturally induced currents (e.g. thunderstorms) whose propagation is measured by EM and resistance methods. This means that the results go much deeper than EM and geoelectrics.

Ground Penetrating Radar (GPR) records radar waves - a type of electromagnetic wave - that are reflected from surfaces and provide a more direct picture of the subsurface - similar to reflection seismology. However, it is usually limited to the uppermost meters of the ground.

Airborne EM survey



Overview of geophysical methods

Geophysics = toolbox for many geoscientific applications



Geophysical Method	Dependent Physical Property	Applications											
		Hydrocarbon exploration	Regional geophysics	Mineral exploration	Engineering/environmental	Groundwater	Subsurface cavity detection	Contaminant plumes	Buried metal objects	Archaeogeophysics	Biogeophysics	Forensic geophysics	Unexploded Ordnance (UXO)
Gravity	Density	P	P	S	S	S	S	-	-	S	-	-	-
Magnetic	Susceptibility	P	P	P	P	-	M	-	P	P	-	-	P
Seismic refraction	Elastic moduli; density	P	P	M	S	S	S	-	-	-	-	-	-
Seismic reflection	Elastic moduli; density	P	P	M	S	S	M	-	-	-	-	-	-
Resistivity	Resistivity	M	M	P	P	P	P	P	S	P	P	M	X
Self-potential (SP)	Potential differences	-	-	P	M	P	M	M	M	-	P	-	-
Induced polarisation (IP)	Resistivity; chargeability	M	M	P	M	S	M	M	M	M	P	M	-
Electro-magnetic (EM)	Conductance; inductance	S	P	P	P	P	P	P	P	P	M	M	P
Ground penetrating radar (GPR)	Permittivity; conductivity	-	-	M	P	P	P	S	P	P	M	P	S
Magnetic resonance sounding	Magnetic moment; porosity	-	-	-	-	P	-	M	-	-	-	-	-
Radiometrics	Gamma - radioactivity	S	S	P	S	-	-	-	-	-	-	-	-

P = primary method; s = secondary method; m = may be used; - = unsuitable



Electrical properties of soils and rocks

Resistivity = resistance of
the ground to passing
electrical current

Electrical resistivity of Earth Materials

Conduction processes

An electric current (I) exists due to the transport of electric charge (q) that results from an applied electric field (E)

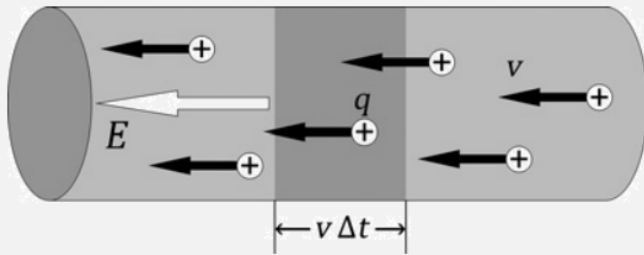

Types of conduction

Electron conduction: charge carried by freely moveable electrons

Other than in ores, electron conduction can be neglected, and mineral grains are assumed to be insulators

Electrolytic conduction: via the ions dissolved within the pore fluid filling the interconnected pore space

Surface conduction: via the ions in the Electrical Double Layer (DL) that forms at the mineral–fluid interface

Electrolytic conduction

Direction of current flow

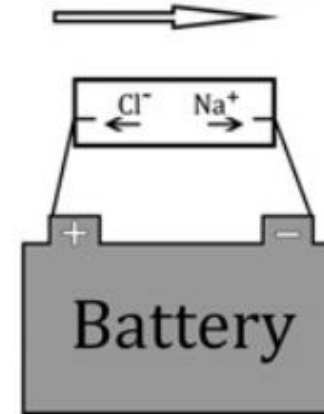

Electron conduction

Direction of current flow

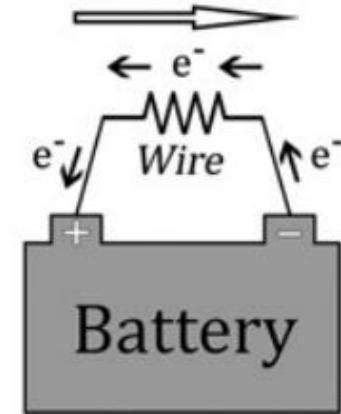

Surface conduction

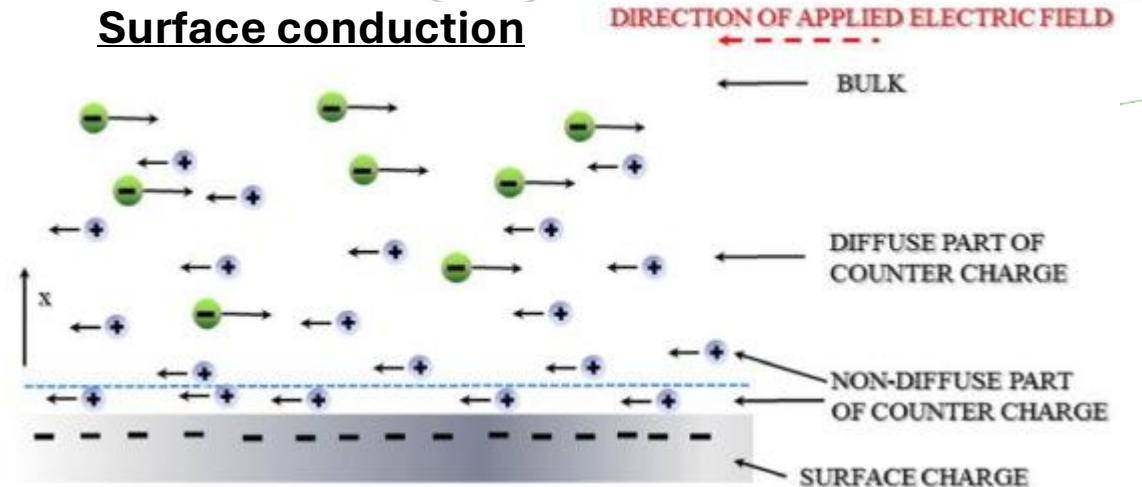

Electrical resistivity of Earth Materials

Conduction processes

An electric current (I) exists due to the transport of electric charge (q) that results from an applied electric field (E)

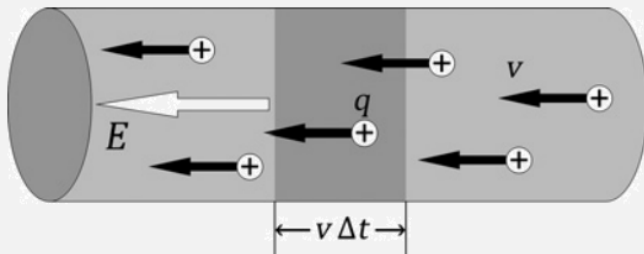

Types of conduction

Electron conduction: charge carried by freely moveable electrons

Other than in ores, electron conduction can be neglected, and mineral grains are assumed to be insulators

Electrolytic conduction: via the ions dissolved within the pore fluid filling the interconnected pore space

Surface conduction: via the ions in the Electrical Double Layer (DL) that forms at the mineral–fluid interface

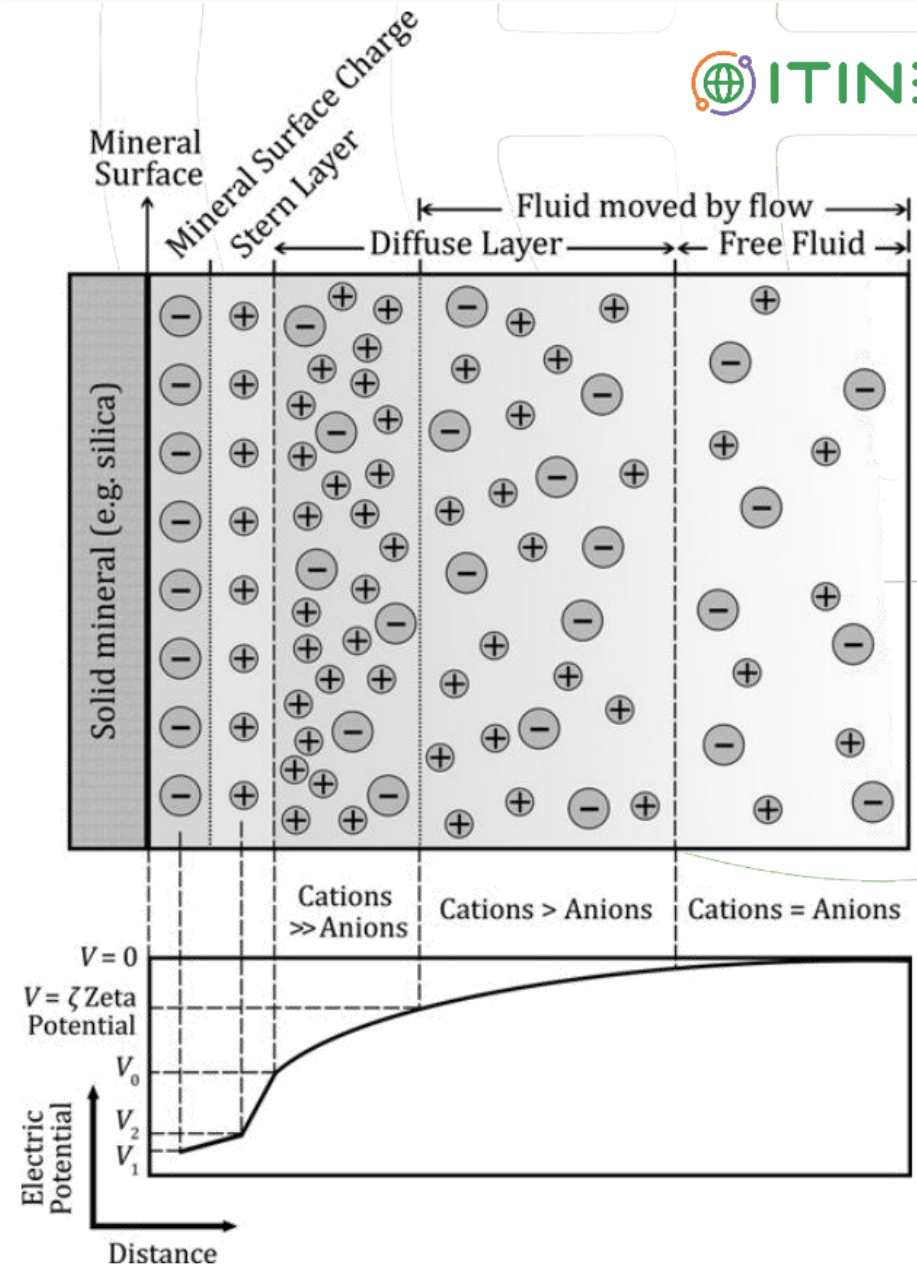

Electrical resistivity of Earth Materials

Conduction processes

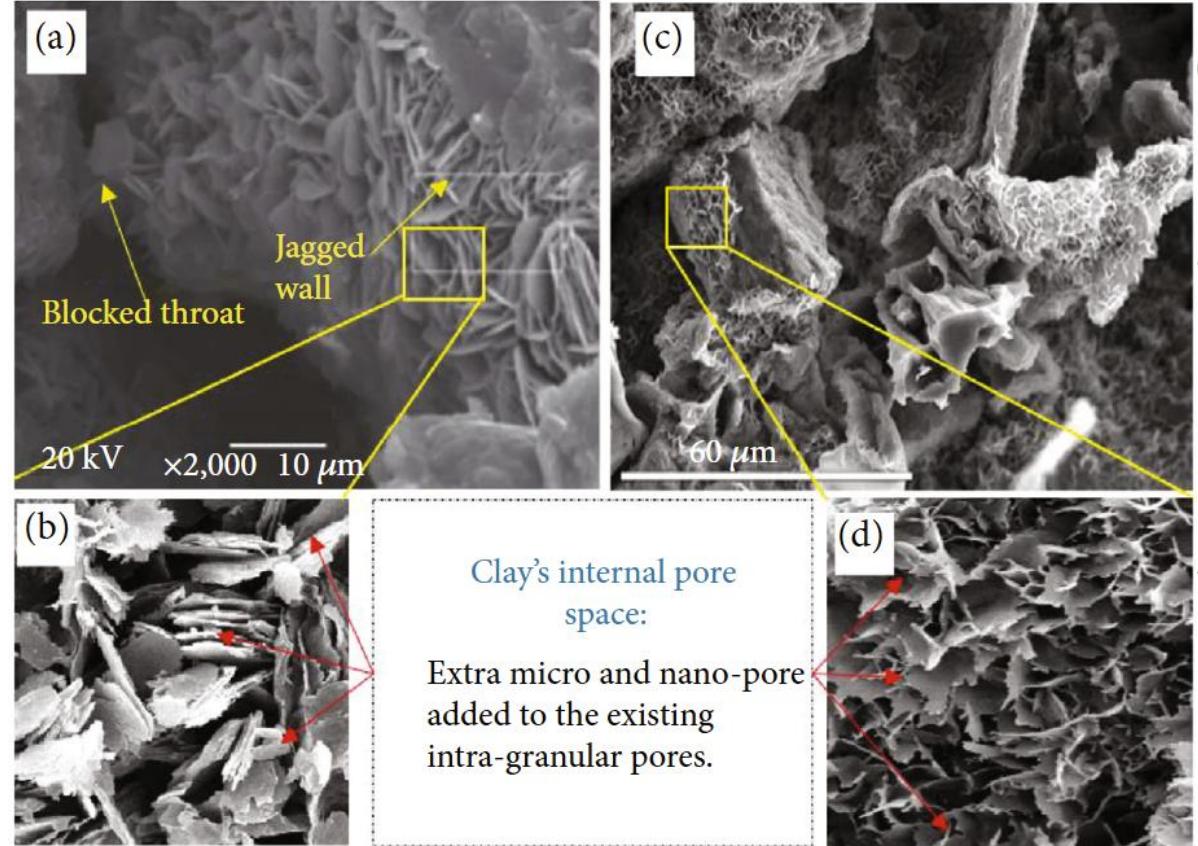
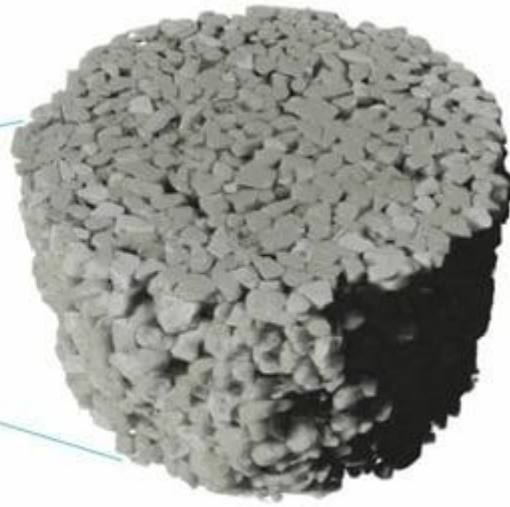
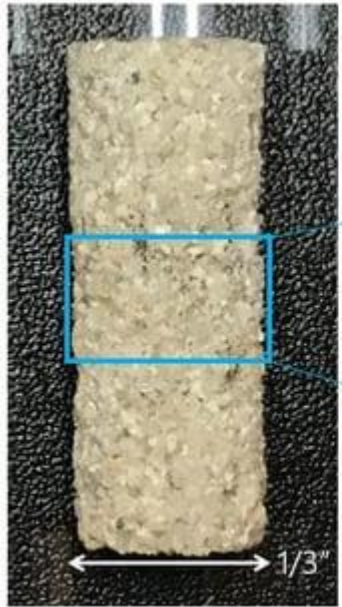

Electrical resistivity of Earth Materials

Conduction processes

Resistivity = resistance of the ground to passing electrical current

Depends on:

- Composition (clay and mineral/metal content)
- Porosity Φ
- Moisture content (Saturation S_w)
- Pore fluid conductivity ρ_w
- Temperature

Models:

Composition Fluid

- **Archie's law** $\rho_b = a\Phi^{-m}S_w^{-n}\rho_w$ (no clay)

$$\rho_b = FS_w^{-n}\rho_w$$

- Temperature dependence

$$\rho_{T20^\circ C} = \rho_b \left(1 + \frac{2.0}{100} (T_{20^\circ C} - T_{sample}) \right)$$

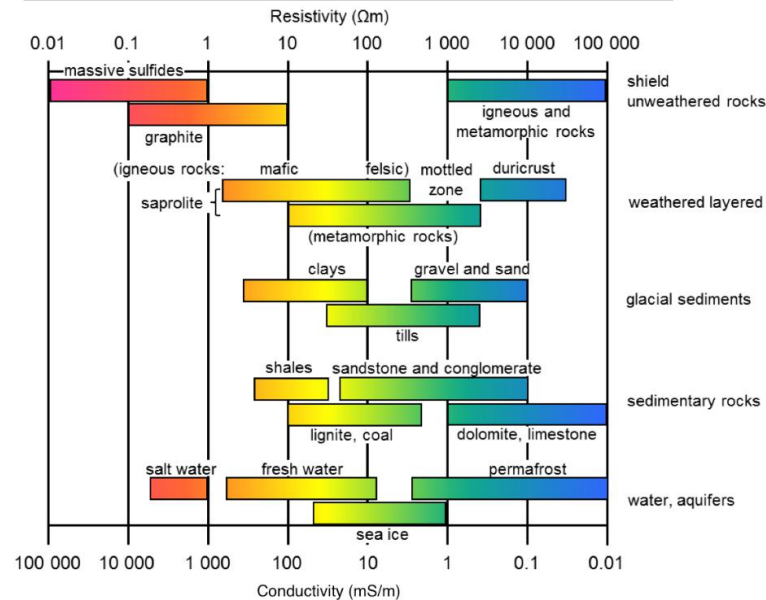
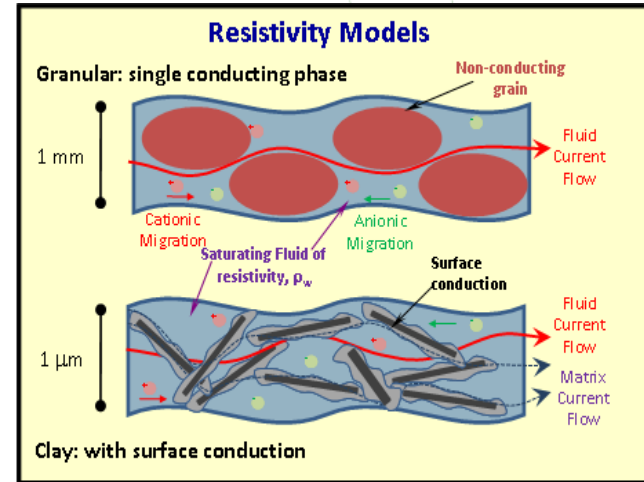

Wet, warm, clay-rich, ion-rich (salty)

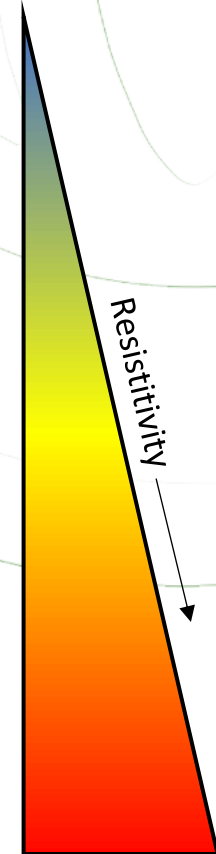

Dry, cold, no clay, ion-depleted

Electrical resistivity of Earth Materials

Landslide features that can be investigated using geophysics

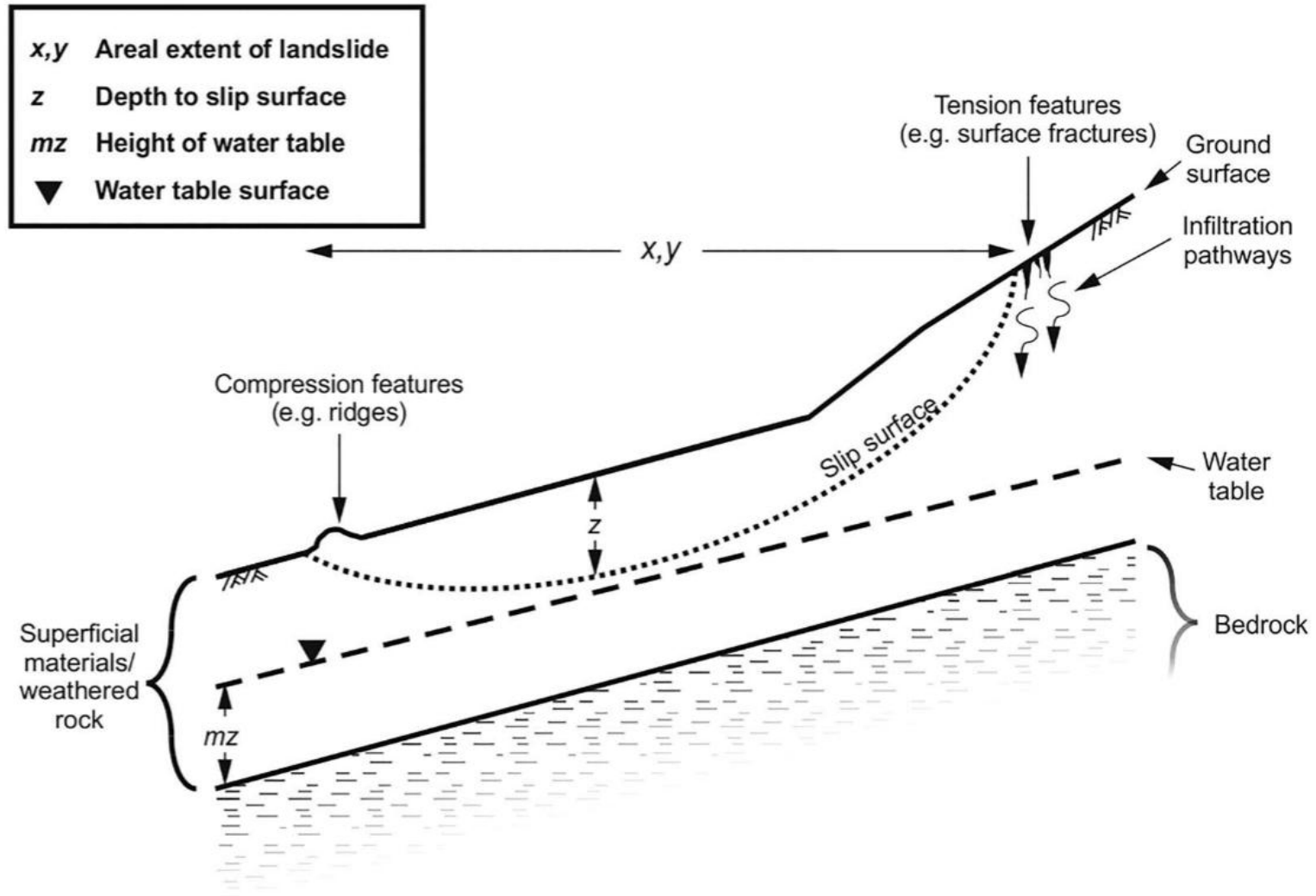

Electrical resistivity of Earth Materials

Landslide features that can be investigated using geophysics – infinite slope model

β	Slope angle	W	Weight
u	Pore water pressure	z	Depth to slip surface
σ	Total normal stress	mz	Height of water table
τ	Shear stress	q	Flow
▼	Water table surface		

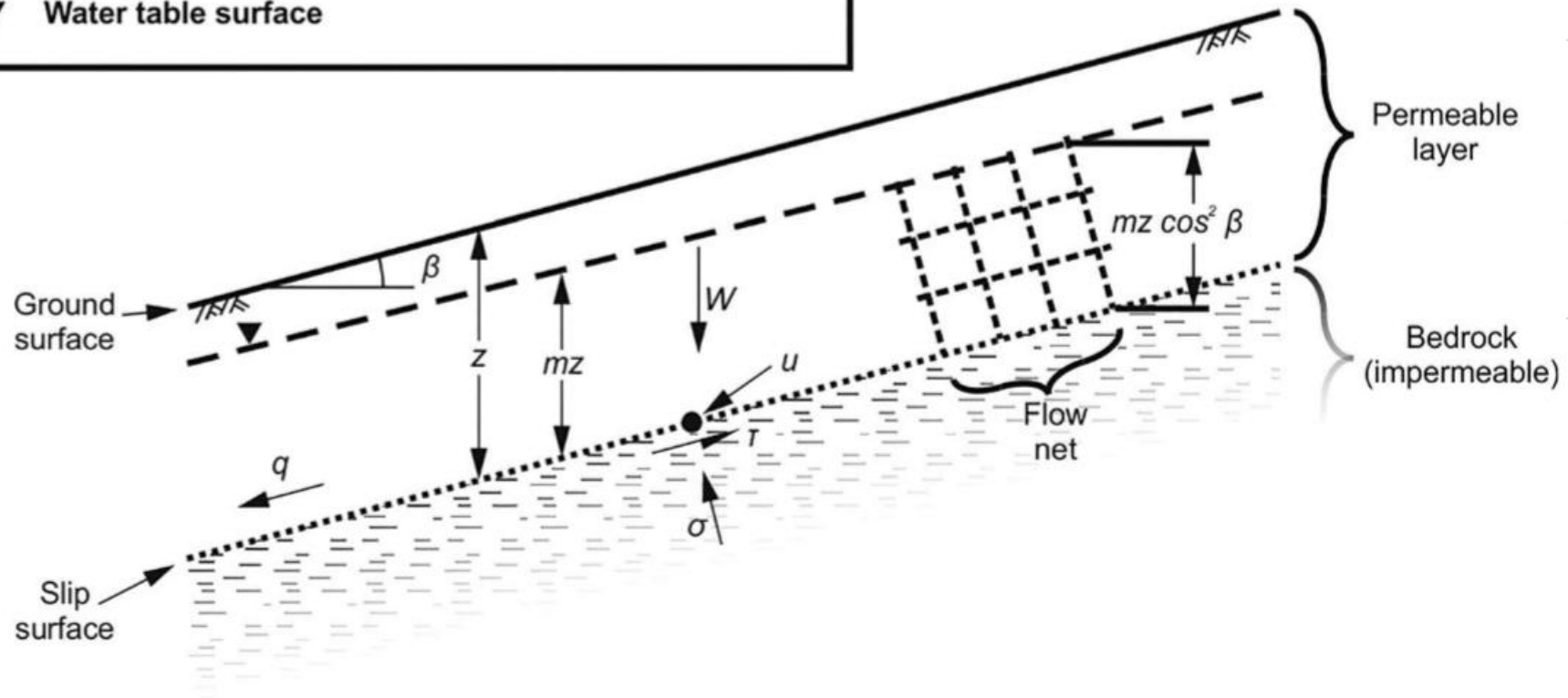

Electrical resistivity of Earth Materials

Soil properties important for landslide studies

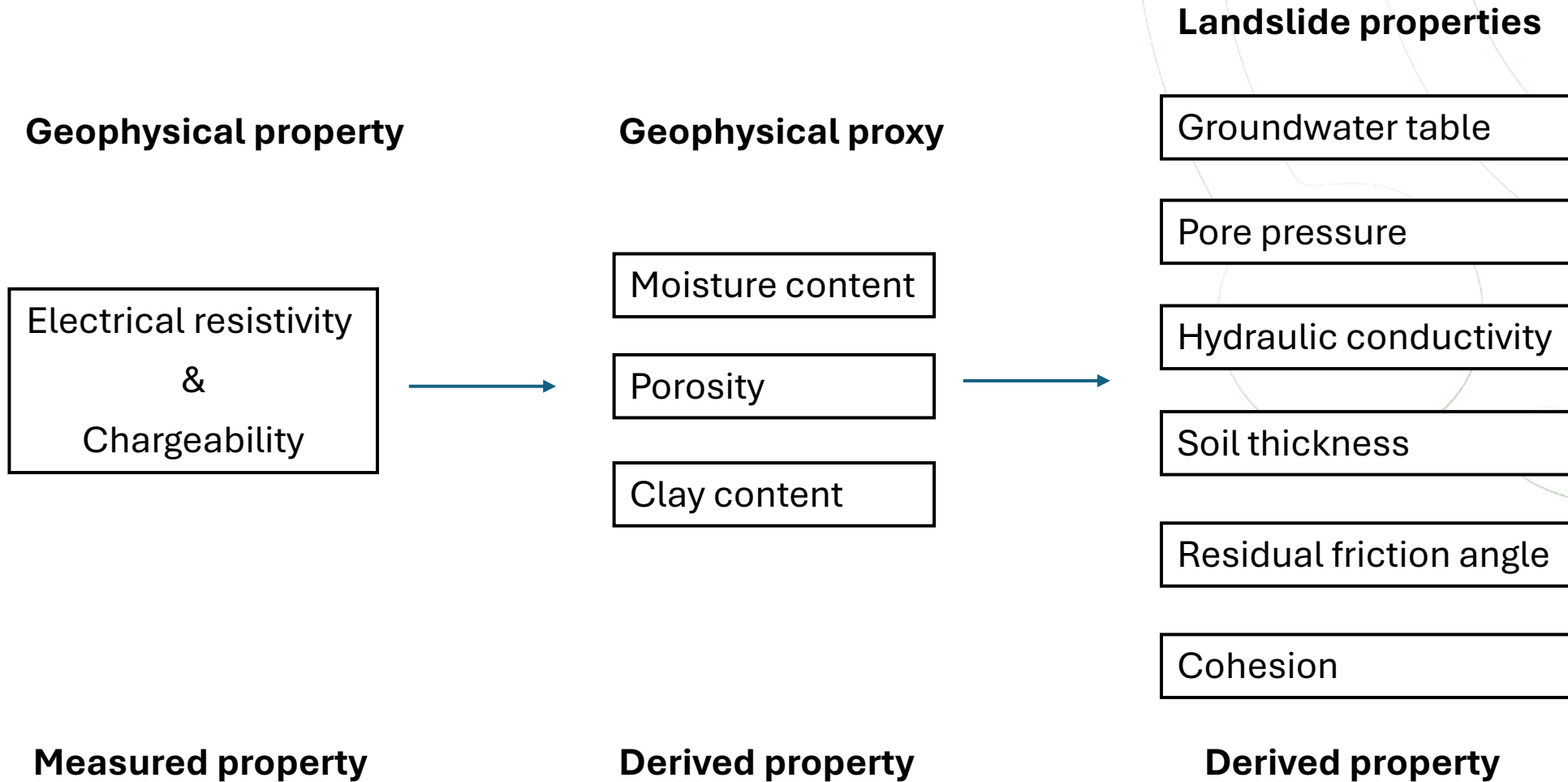

Archie's equation

Empirical relationship between the electrical resistivity of rock and pore fluid properties

Tortuosity factor

- Related to path length of current flow
- Sensitive to variation in compaction, pore structure, grain size
- Ranges between 0.5 to 1.5

Cementation exponent

- Related to the pore network, connectivity
- Increasing with increasing cementation
- Ranges between 1.3 – 4.1

Saturation exponent

- Related to the wettability of the rock
- Usually fixed to 2

$$\rho_s = a\Phi^{-m}S^{-n}\rho_w = FS^{-n}\rho_w$$

Bulk resistivity

Porosity

Saturation

Pore water resistivity

Formation factor

Sensitivity of Archie's equation

Varying impact on the bulk resistivity

- Soil resistivity **very sensitive to Saturation and Porosity**
- Also **sensitive to cementation and pore-water resistivity**
- **Not sensitive to Tortuosity factor and saturation exponent**

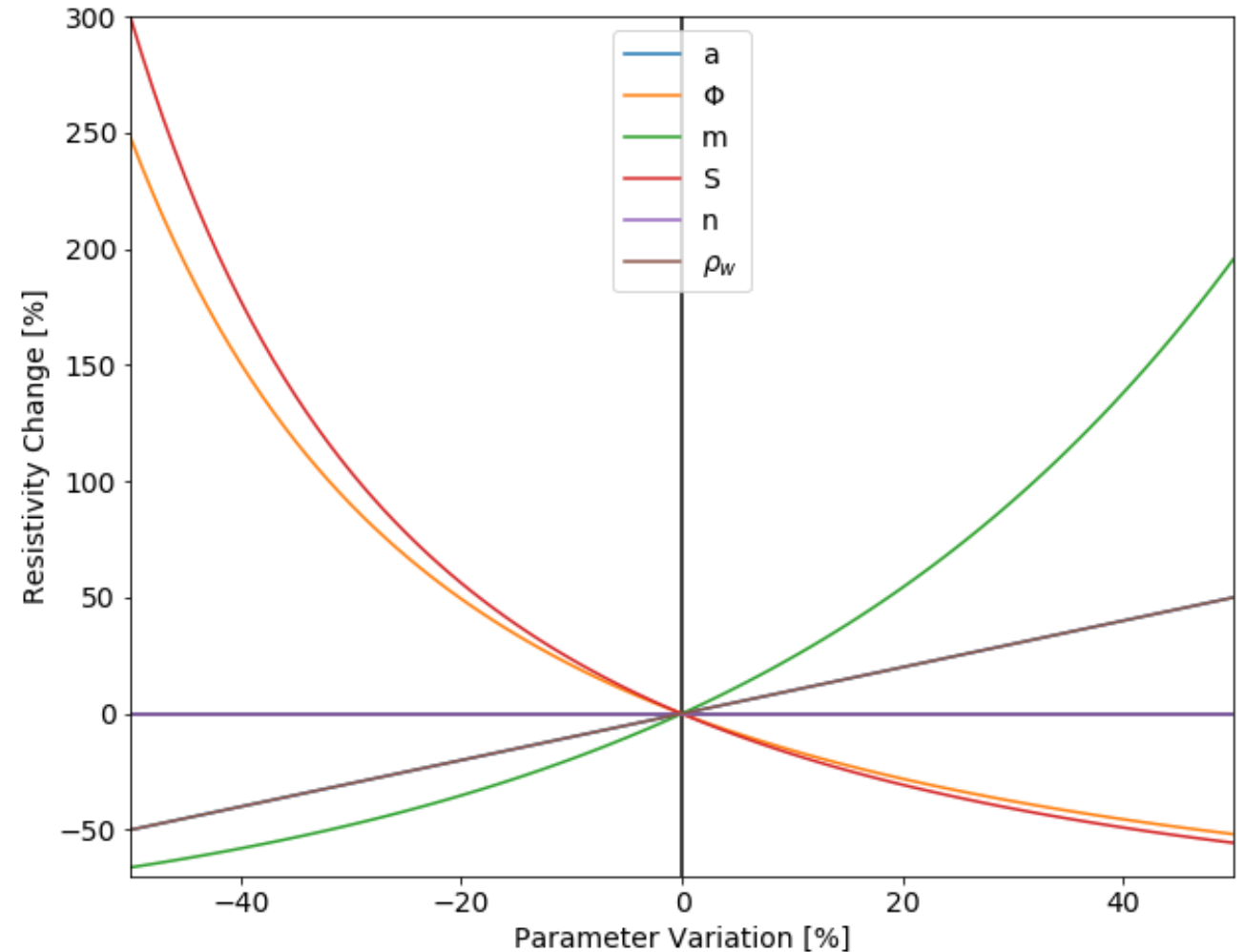

Sensitivity of Archie's equation

Effect of saturation and porosity

Increasing saturation and porosity decreases the resistivity

- Resistivity is sensitive to changes in moisture content
- Drying will decrease saturation and increase resistivity
- Higher sensitivity to changes in saturation than to porosity

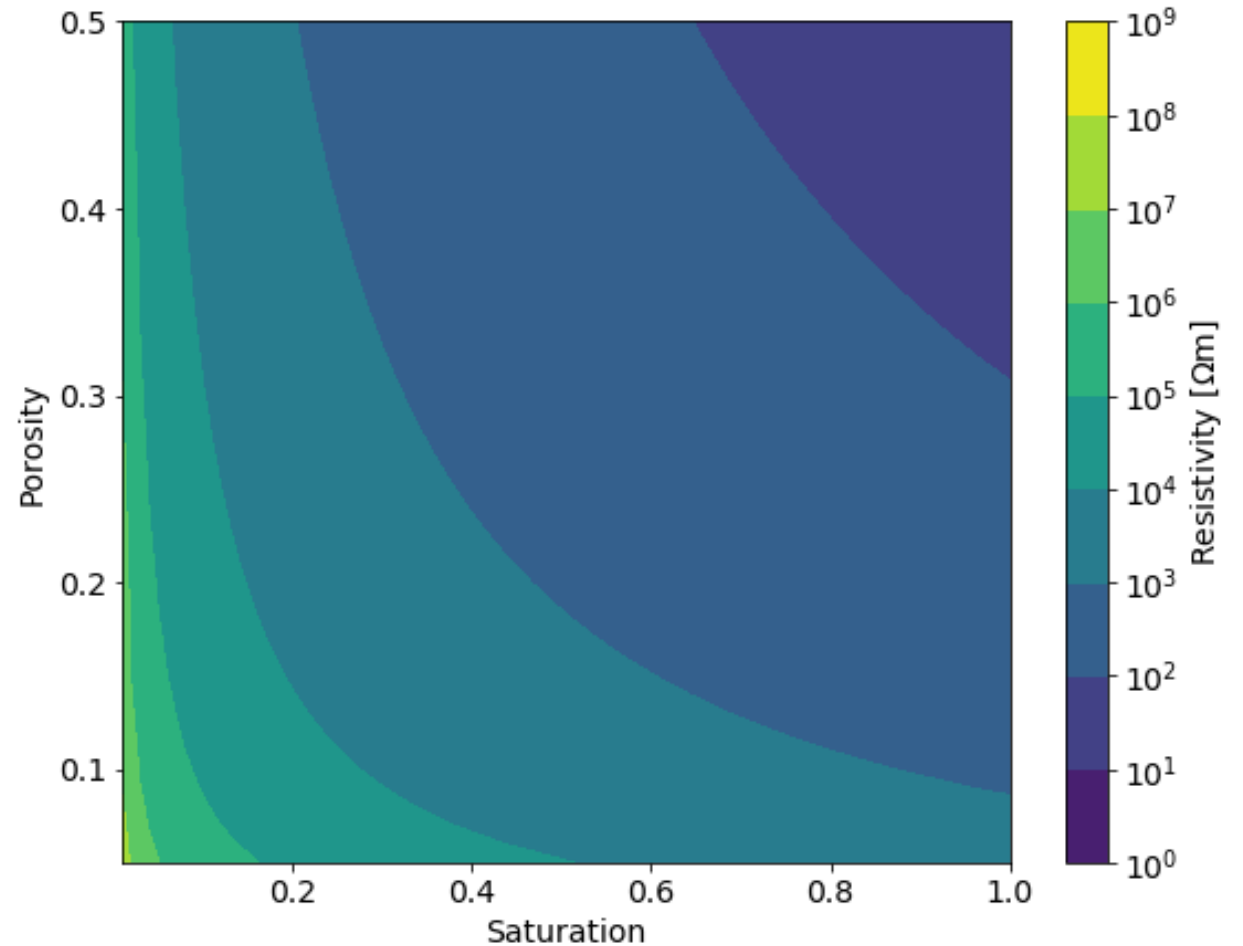

Summary of Archie's equation

Benefits and Drawbacks

Benefits

- Easy formula
- Limited amount of variables
- Good approximation for clean rocks (sandstone/limestone/igneous rocks)

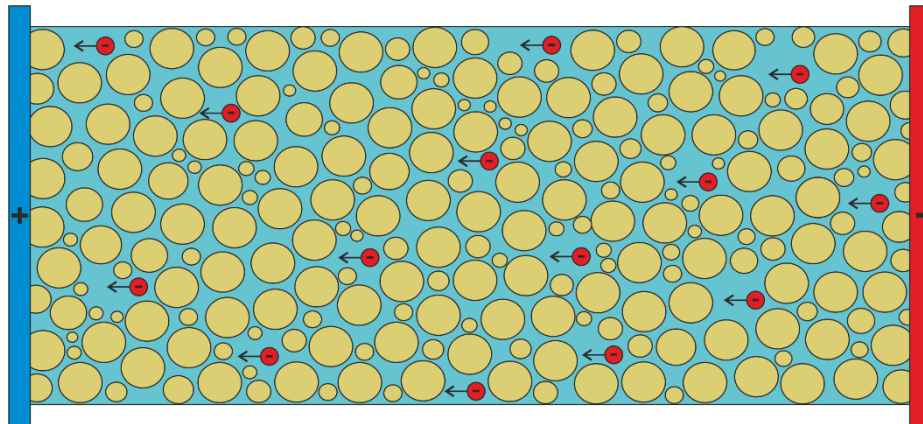

Drawbacks

- Considers **electrolytic conduction** only
- Not suitable for rocks and soils containing clays (**surface conductivity**)

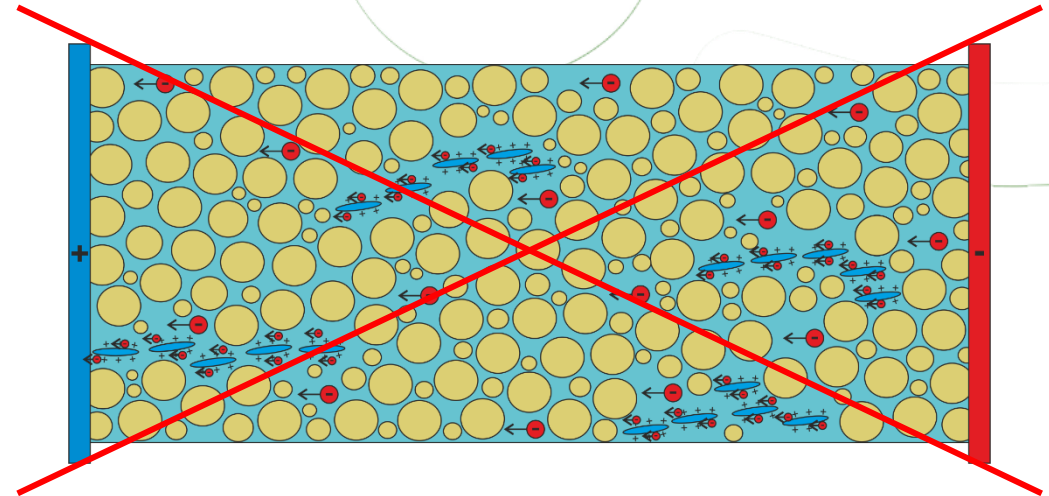

Waxman-Smiths equation

Accounting for surface conduction

Cation concentration per unit volume

Ion mobility

$$\rho_s = FS^{-n}\rho_w + \rho_{\text{surface}} = \frac{F}{S^n} \left(\frac{1}{\rho_w} + \frac{BQ_v}{S} \right)^{-1}$$

Particle density

$$Q_v = \frac{(1 - \Phi)d_g c}{100\Phi}$$

Cation exchange capacity

- Measure of how many cations can be retained on soil particle surfaces
- Unit: cmol_c/kg

$$B = 4.6 \left(1 - 0.6e^{-\frac{1}{1.3\rho_w}} \right)$$

Waxman-Smiths equation

Cation-Exchange capacity linked to clay content

- Resistivity decreases with increasing Cation Exchange Capacity = increasing clay content
- Even small amounts of clay lower the resistivity considerably
 - Clay content is an important parameter for electro-petrophysical relationships

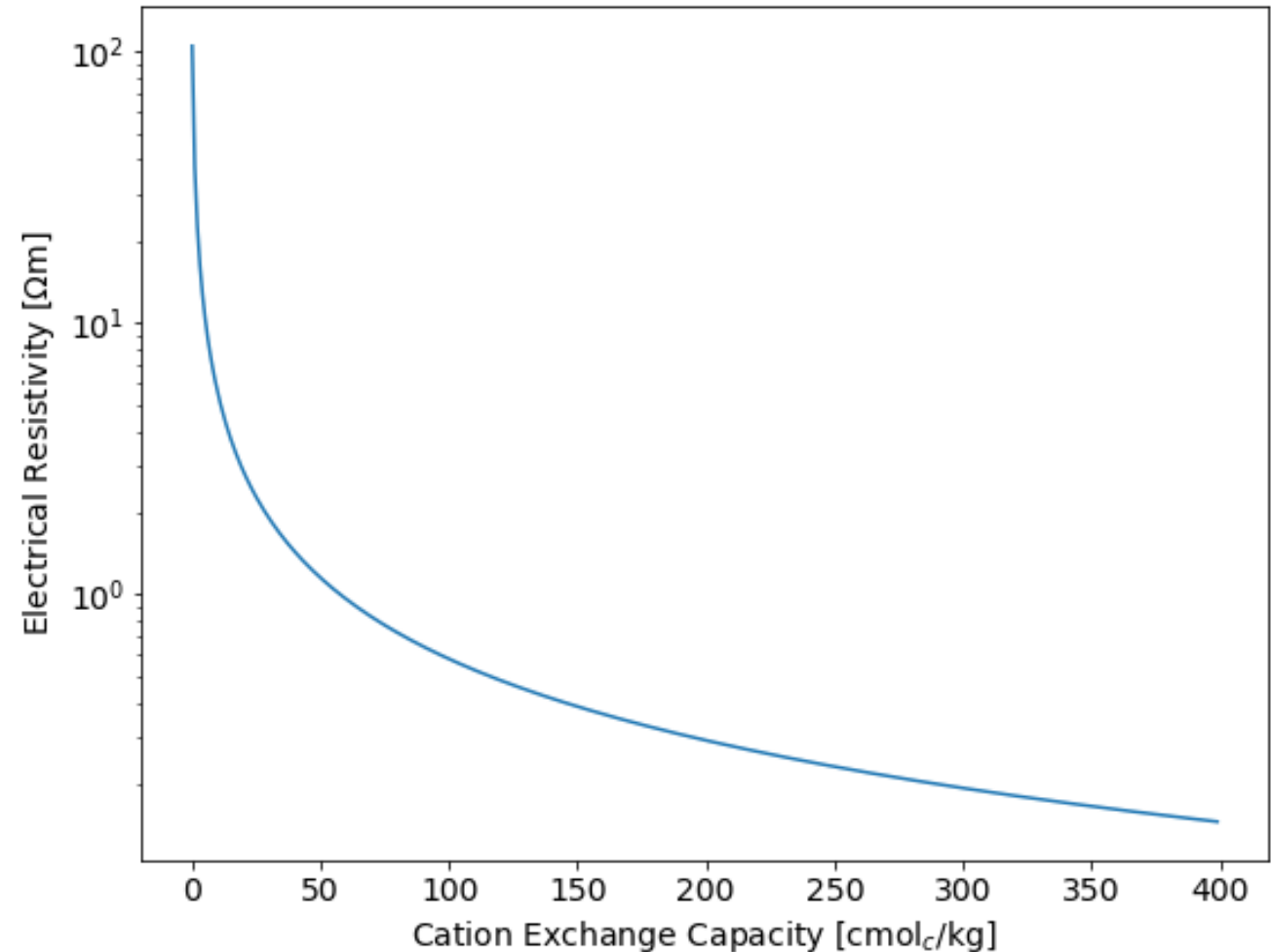

Electro-petrophysical relationships

A story of water and clay

- Resistivity of soils is **very sensitive to changes in moisture content** and clay content
- Monitoring: Clay content can usually be assumed to be constant over time.
 - This does not mean that we can neglect surface conduction in monitoring applications. Contribution depends also on the saturation and the pore fluid conductivity!

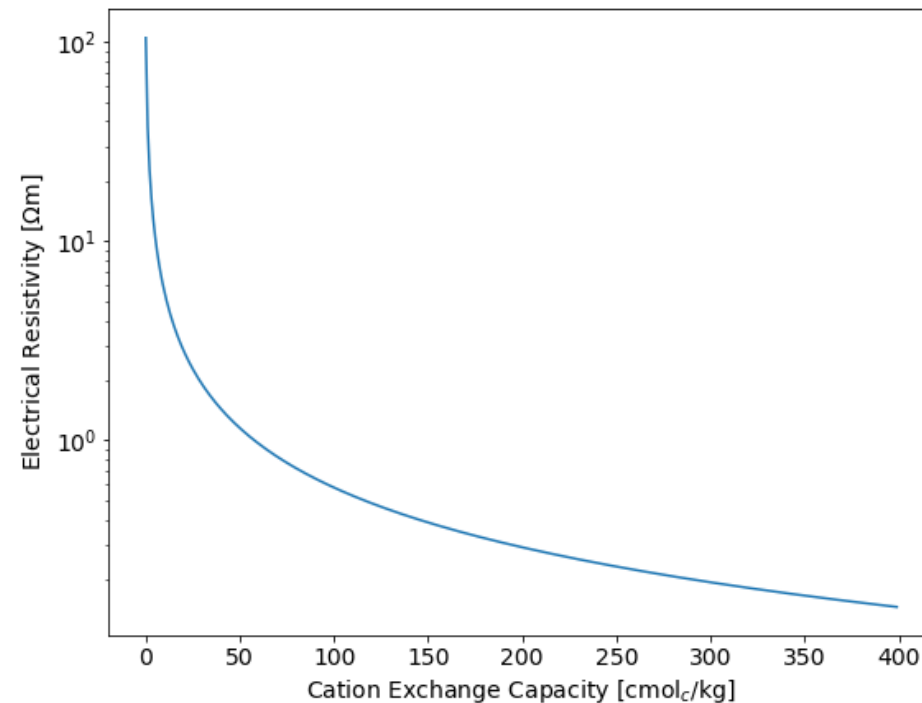
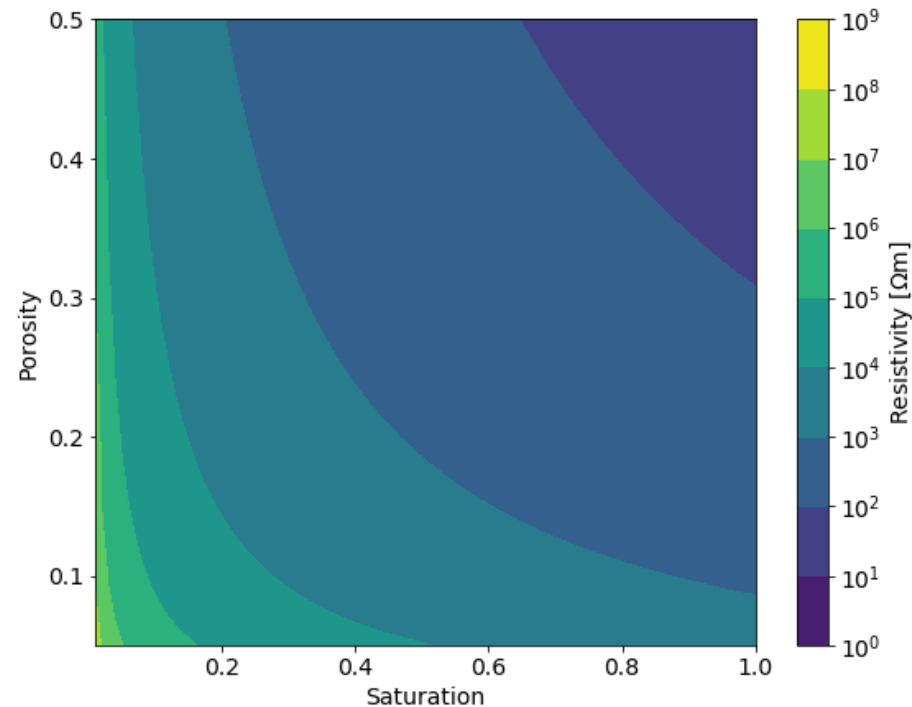

Electro-petrophysical relationships

A story of water and clay

Problem:



Model & physical properties:

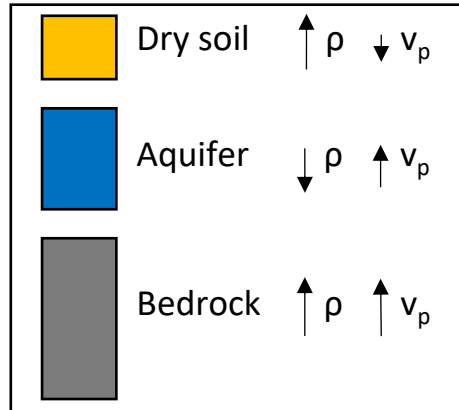

Geoelectrical measurement:

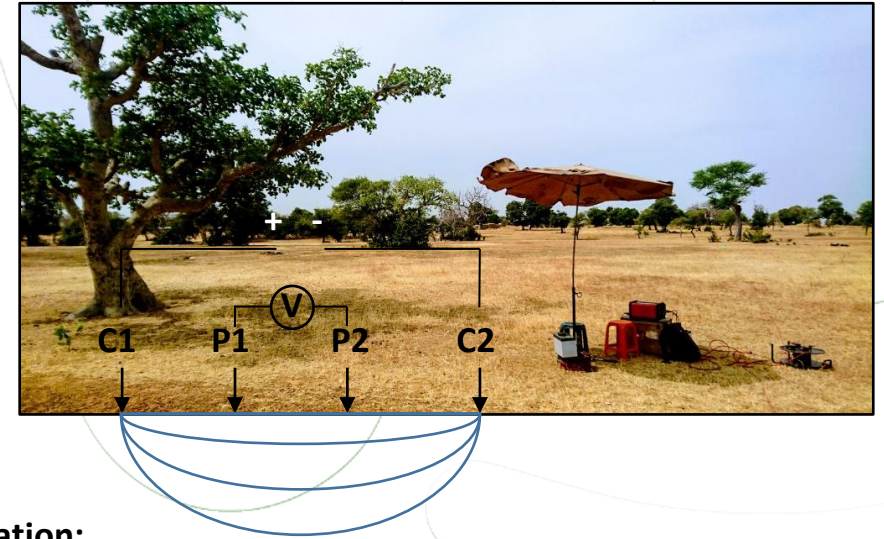

Result:



Data processing and interpretation:

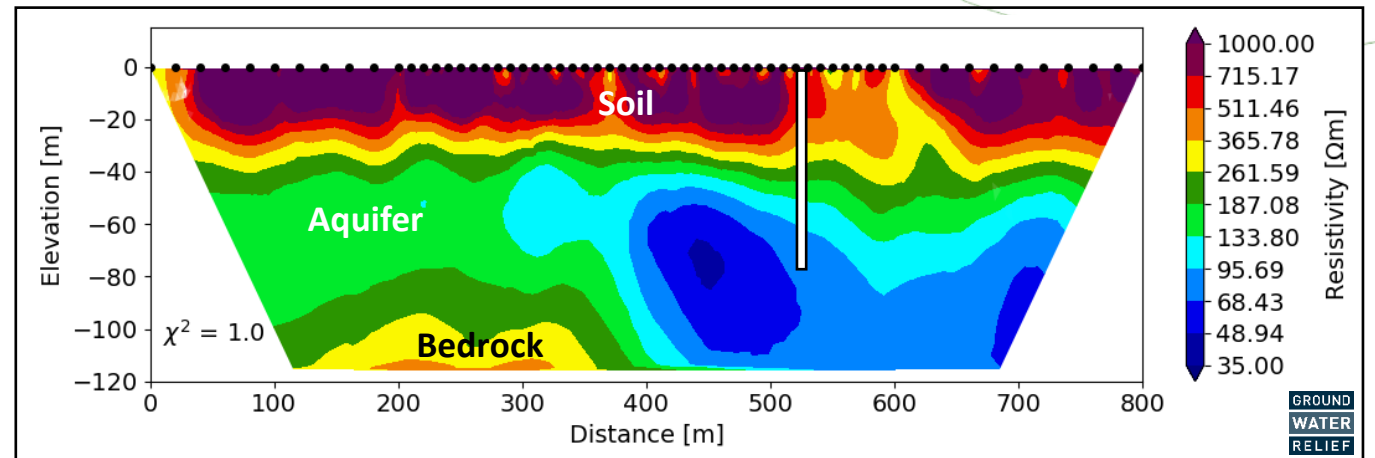

Data courtesy of Groundwater Relief

Electrical resistivity of Earth Materials

Soil properties important for landslide studies

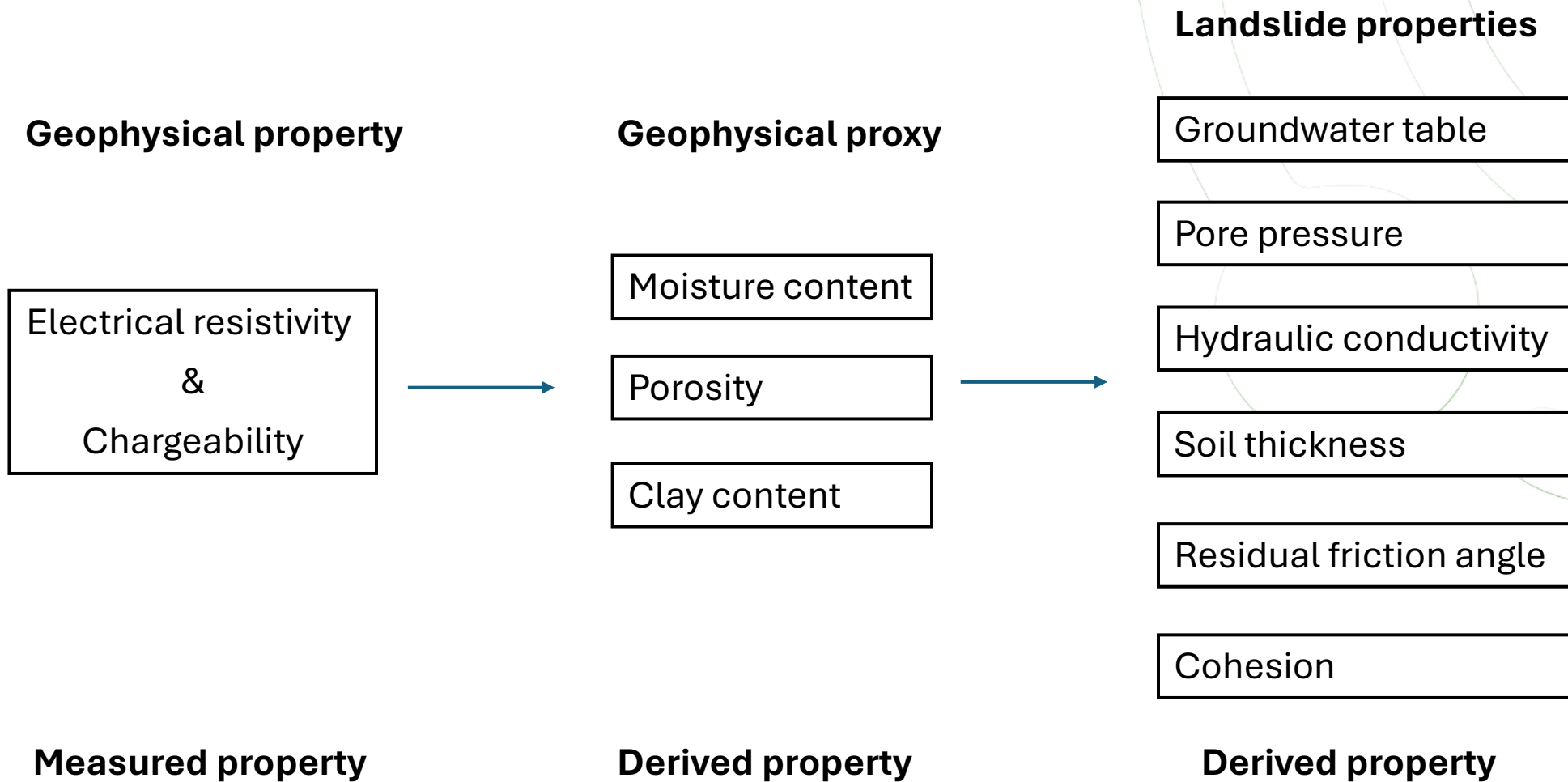

Lab measurements to determine the resistivity of soils or rocks

Establishing petrophysical relationships

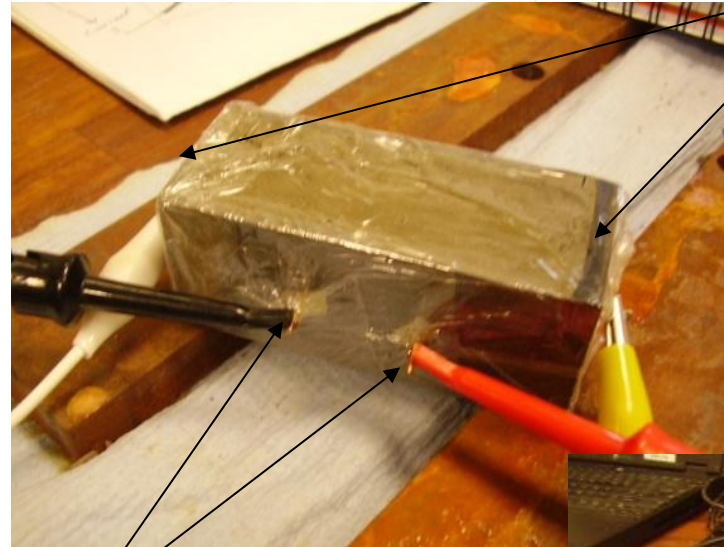
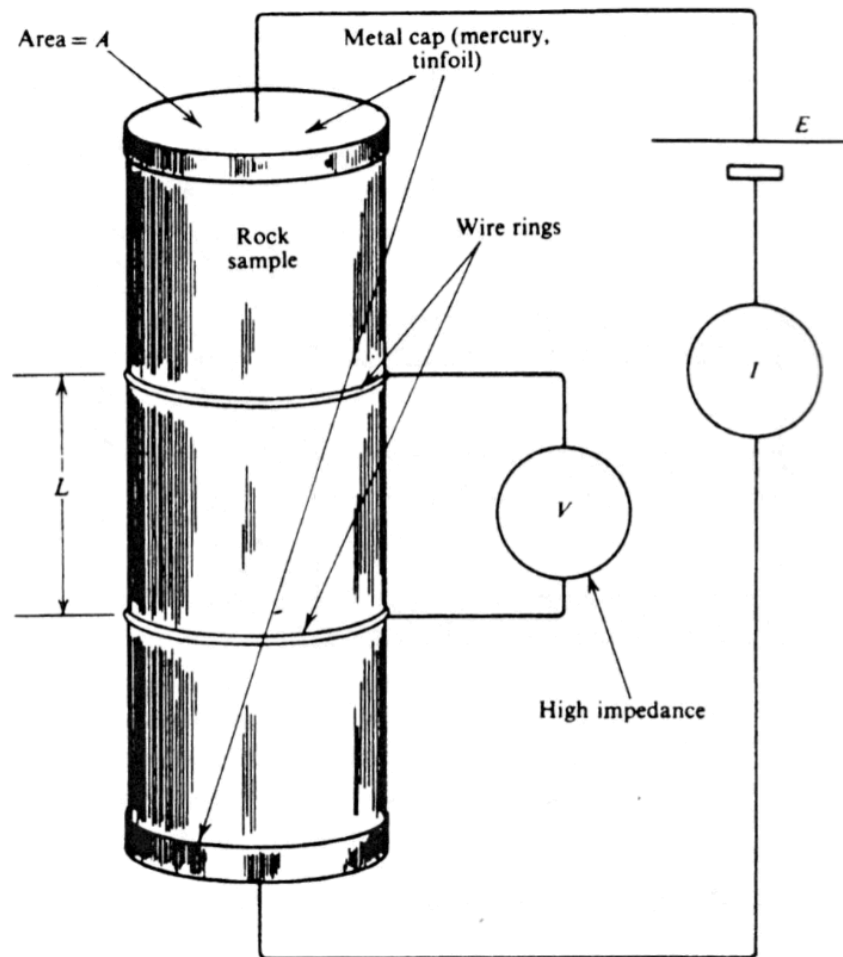

Current electrodes

Voltmeter (Oscilloscope)

Potential electrodes

Current source

Reference resistor

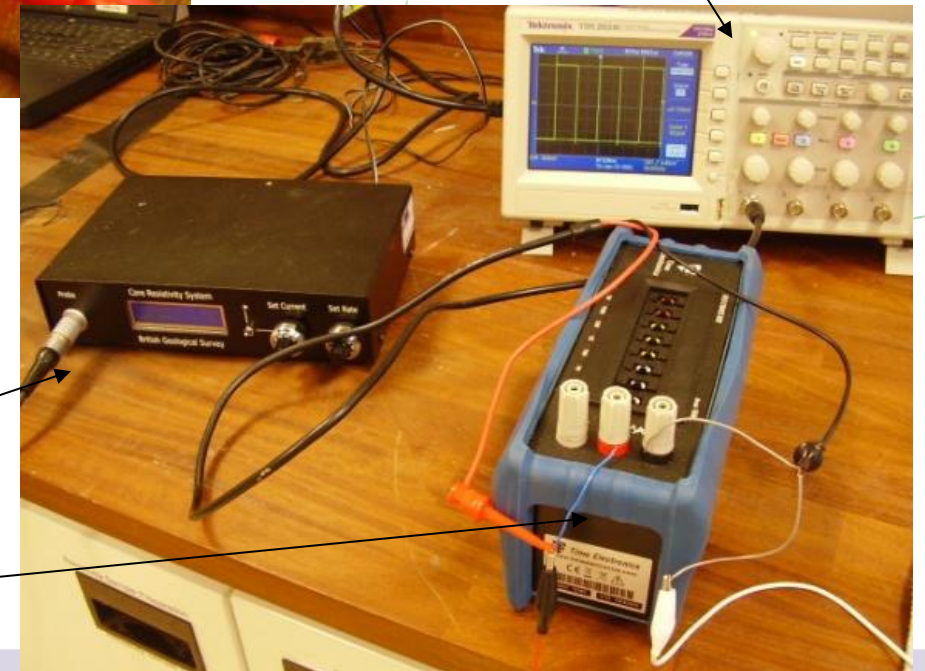

Establishing petrophysical relationships

Fitting model to the data

- Samples have undergone wetting and drying cycles
- Resistivity measured at different stages
- Waxman-Smiths model fitted to the data, i.e. finding model parameters by minimizing the difference between model and data
 - **Known data:**
 - Particle/Water density
 - CEC
 - Pore water conductivity
 - (Porosity)
 - **Unknown:**
 - Formation factor
 - Saturation exponent
 - (Porosity)

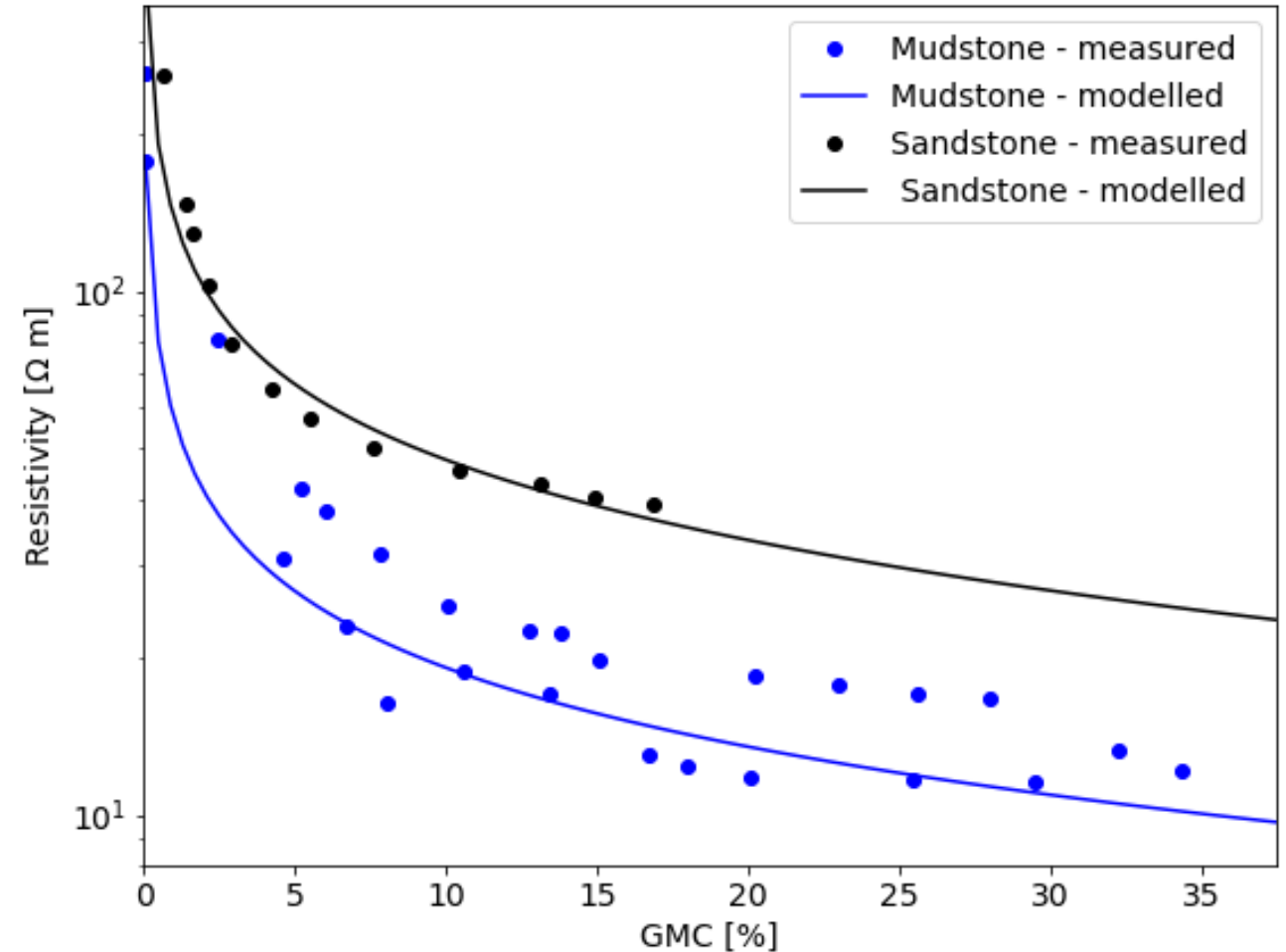

Assessing variations in geomechanical parameters

Translating electrical measurements to matric potentials

Practical considerations for using petrophysics and geoelectrical methods on clay rich landslides

1. Geophysics on Landslides

The electrical properties of the ground are useful for illuminating the subsurface geology, here we study an active landslide.

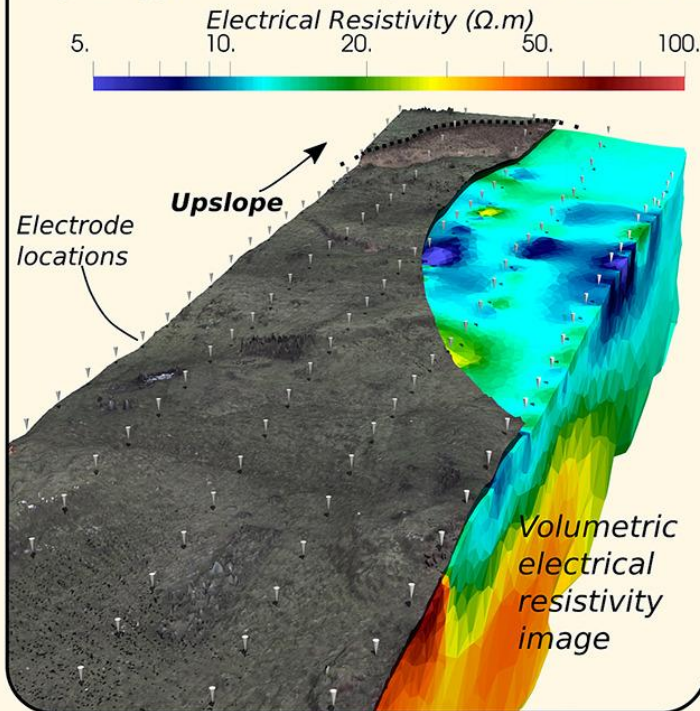

2. Petrophysics

Landslides occur due to changes in soil hydrology. Electrical resistivity measurements can be used to help evaluate stress states in the soil like matric potential.

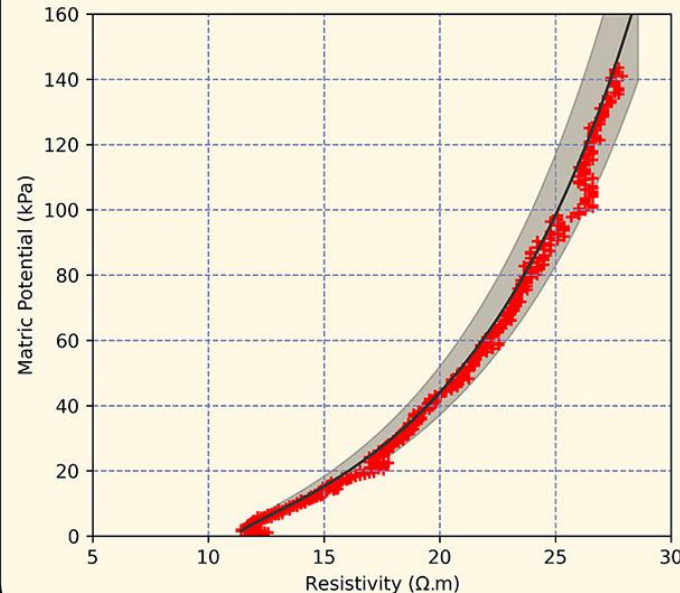

3. Joint Interpretation of Slope

Converting geophysical states (electrical resistivity) to matric potential allows for an assessment of slope stability.

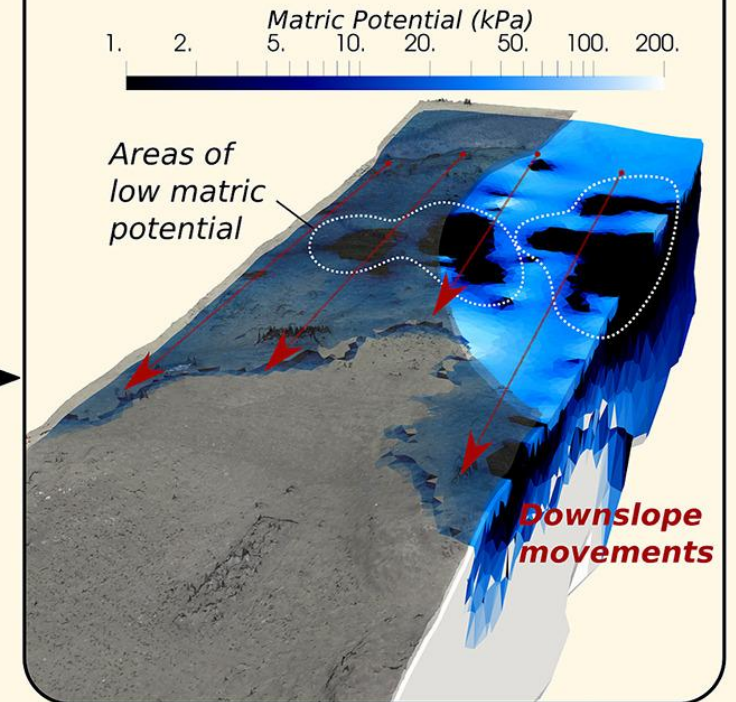

Boyd et al., 2024

Linking geophysical with hydrogeomechanical parameters

Summary

Electro-geophysical properties are highly sensitive to variations in moisture content = saturation

Measured value: electrical resistivity ρ (or changes in ρ)

Petrophysical relationships, e.g., Archie's law or Waxman-Smiths model, link resistivity with formation and fluid properties

No direct measurements of hydrogeomechanical parameters! Only proxy measurements.

Geophysical measurements and monitoring provides high resolution data that needs to be treated carefully!

Link to other observations (boreholes, environmental data, remote sensing data, ...)

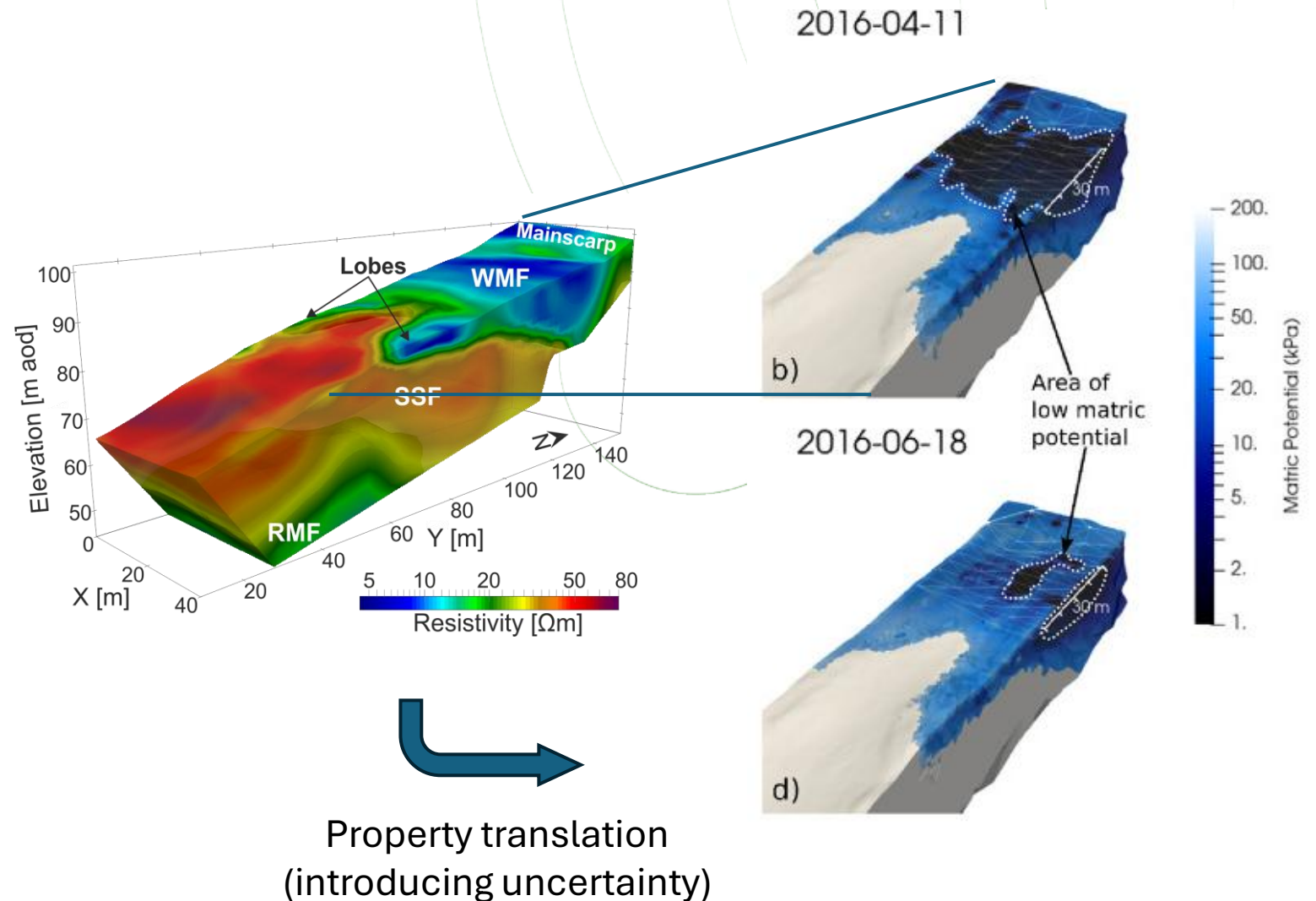



THANKS!

IR0000032 – ITINERIS, Italian Integrated Environmental Research Infrastructures System
(D.D. n. 130/2022 - CUP B53C22002150006) Funded by EU - Next Generation EU PNRR-
Mission 4 "Education and Research" - Component 2: "From research to business" - Investment
3.1: "Fund for the realisation of an integrated system of research and innovation infrastructures"

