



# Eddy Covariance theory and practice: from sensors setup to preliminary data processing

Module: **Storage flux term**

- Giacomo Nicolini

**IR0000032 – ITINERIS, Italian Integrated Environmental Research Infrastructures System**  
(D.D. n. 130/2022 - CUP B53C22002150006) Funded by EU - Next Generation EU PNRR-  
Mission 4 "Education and Research" - Component 2: "From research to business" - Investment  
3.1: "Fund for the realisation of an integrated system of research and innovation infrastructures"



**Ministero  
dell'Università  
e della Ricerca**



# INTRO

1. Storage term: what is it
2. How to measure it
3. How to compute it
4. Profile and storage flux dynamics
5. Key points



# 1. Storage term: what is it

$$NEE \cong FC + SC$$

- *Formally*: the vertical integral of concentrations time derivatives
- *Practically*: column-average concentrations time differentials
- Cause: accumulation of air in the canopy space when turbulence is low > instantaneous underestimation
- mostly in the lower part (soil contribution)
- mostly during night/sunrise
- Depletion of air from the canopy space when turbulence restarts

## 2. How to measure the storage term

### Random points measurement [gas] measurements randomly spread into the control volume

- sample both vertical and horizontal gradients
- theoretically correct
- basically impossible to implement (technically)

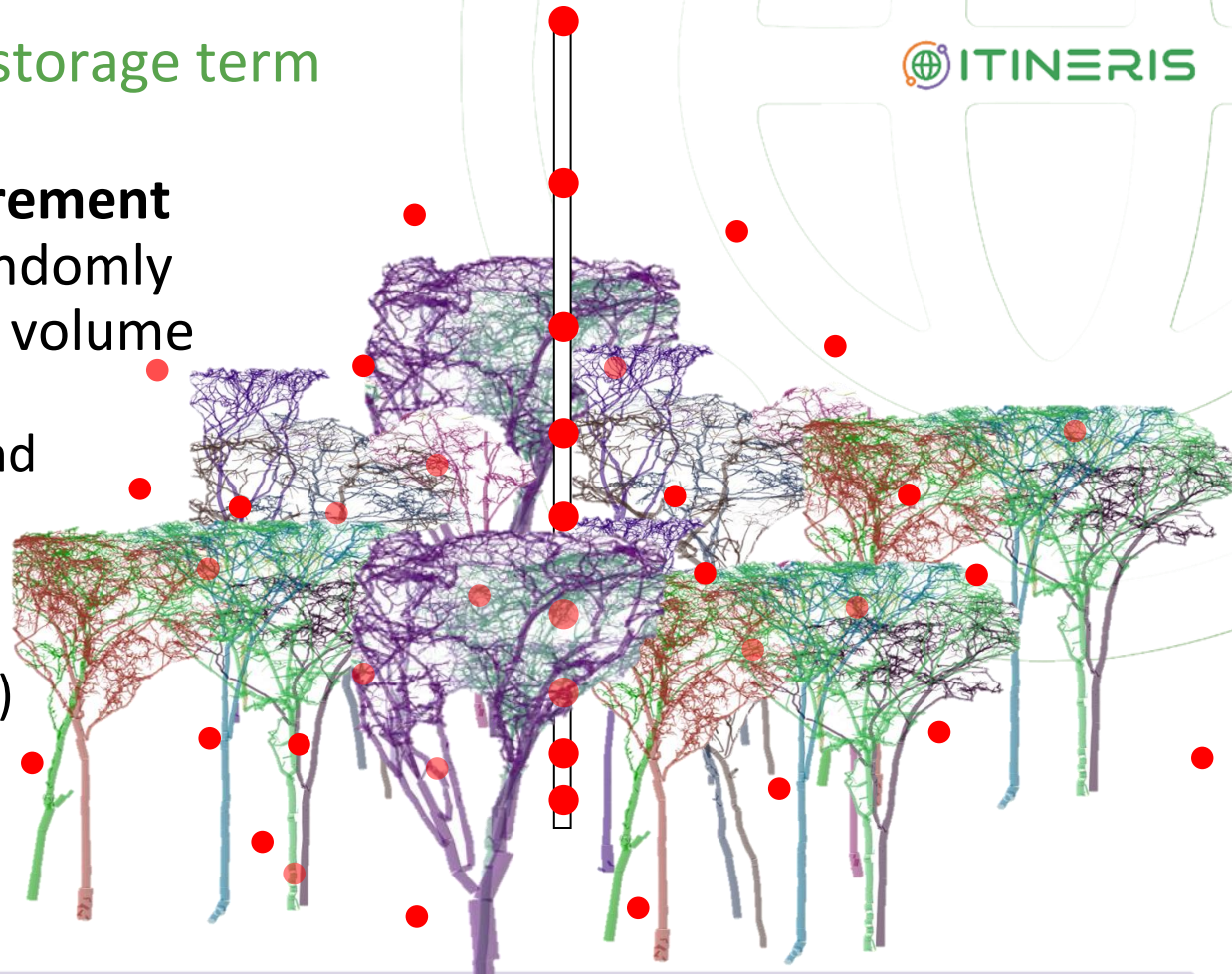

## 2. How to measure the storage term

### Profile measurement

[gas] measurements at several heights

- common approach
- stronger gradient near the surface: increase sampling density

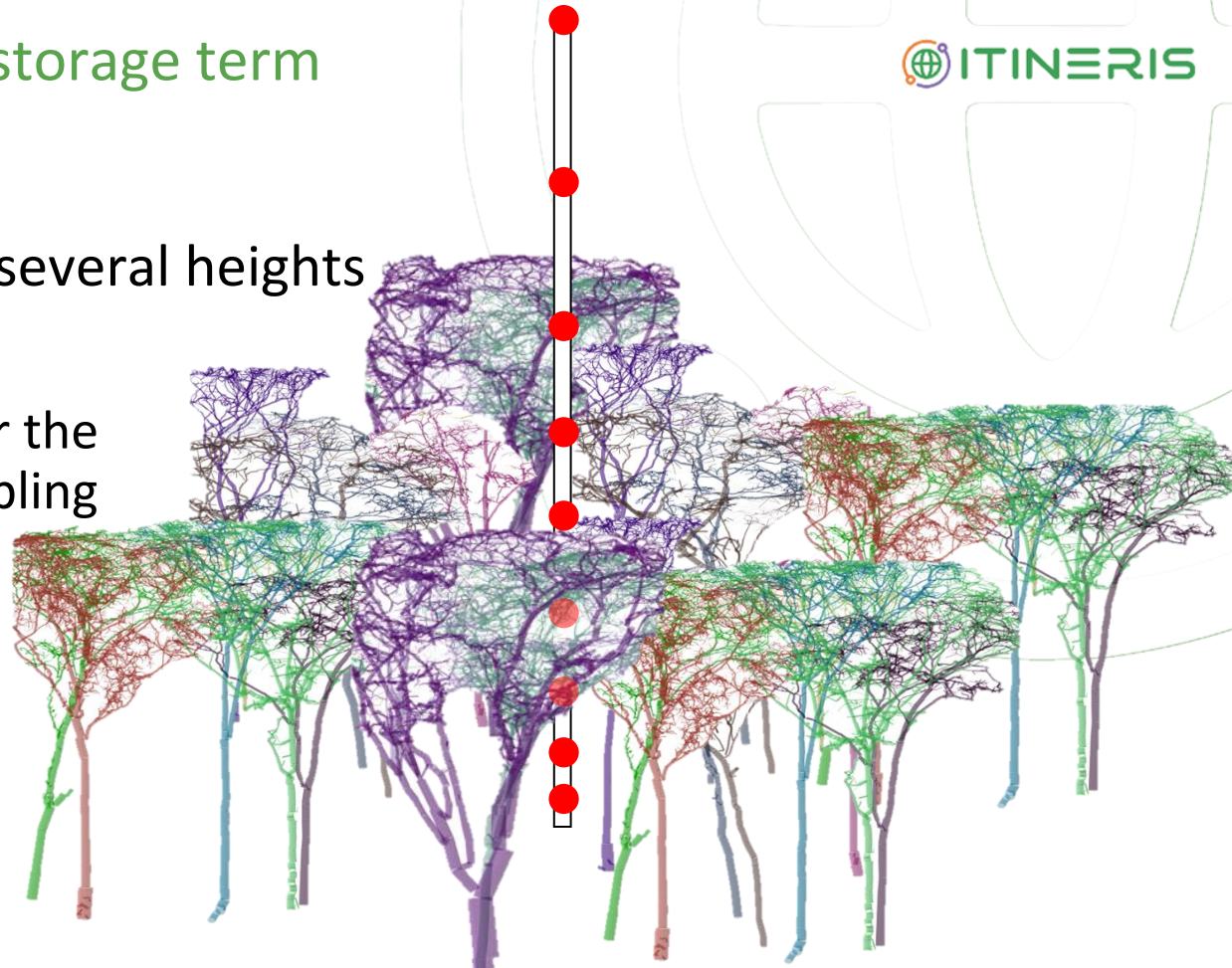

## 2. How to measure the storage term

### Single point measurement [gas] measurements at the EC level

- assumes a constant vertical gradient
- it's a simplification  
>> underestimation!

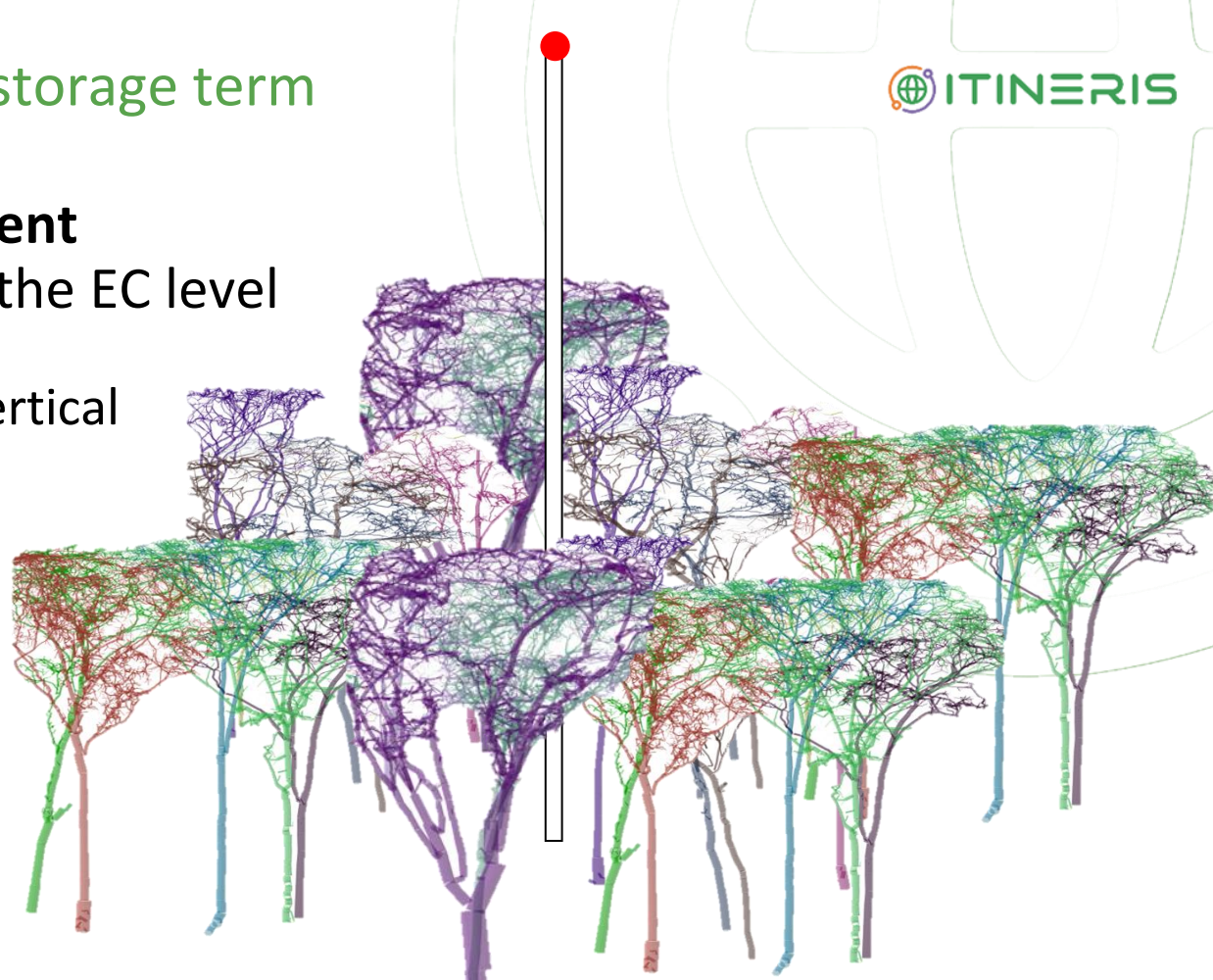

## 2. How to measure the storage term

### Profile + multiple low measurement [gas] measurements at critical points

- sample both vertical and horizontal gradients
- close to the theoretically correct approach
- technically feasible

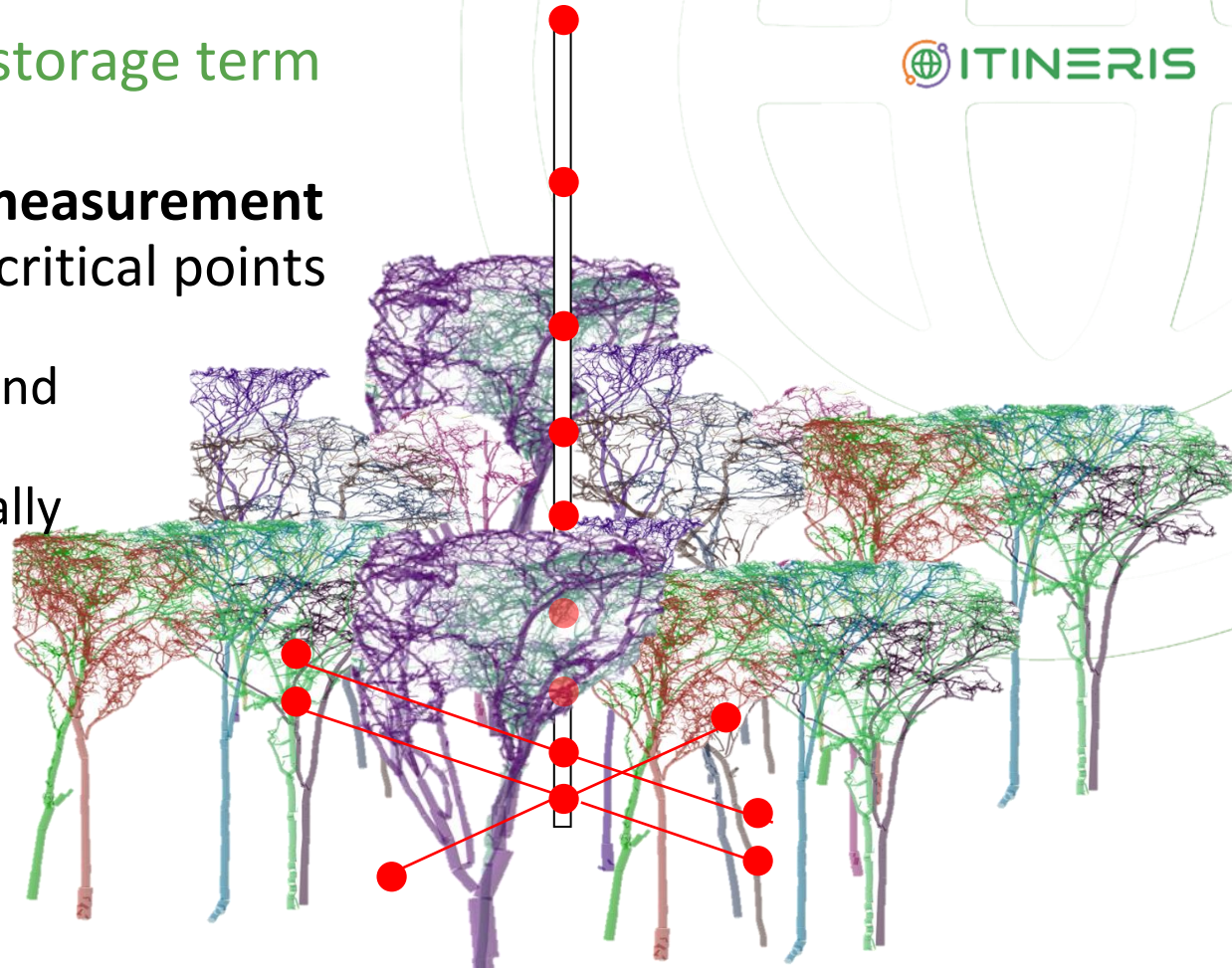

## 2. How to measure the storage term

### Sampling system

#### Basic installation equipment

- Gas analyser(s)
- Pump (one or two)
- Tubing
- Valves and manifolds
- Mass-flow controllers
- Buffer volumes
- Data logger / system controller
- Thermo-hygrometers  
(energy and heat storage!!)

## 2. How to measure the storage term

### Sampling system

#### 1) Separate sampling

**PRO:** allow for instantaneous sampling

**CONS:** implementation costs

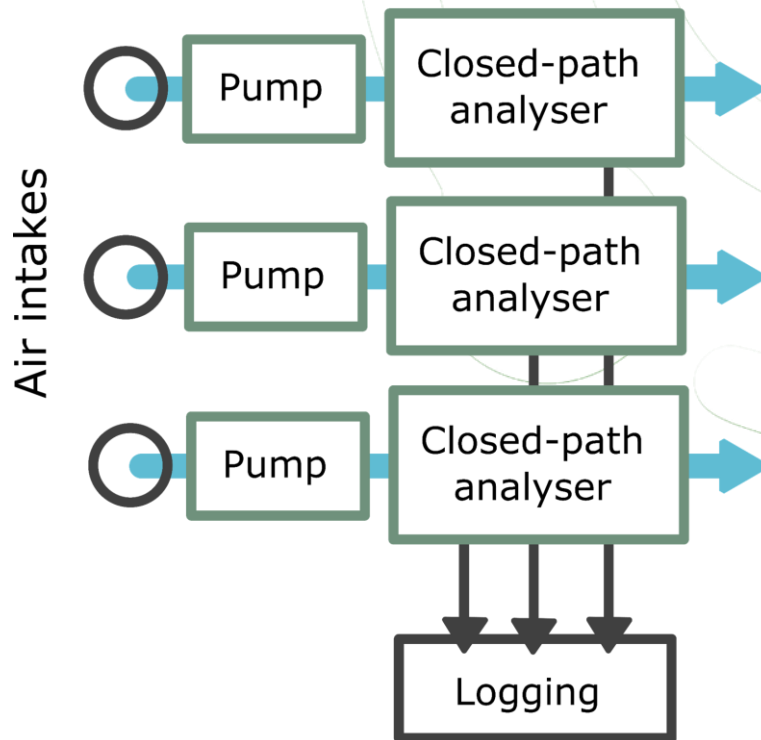

## 2. How to measure the storage term

### Sampling system

#### 2) Simultaneous sampling

**PRO:** allow for instantaneous sampling and physical vertical integration

**CONS:** tricky set-up

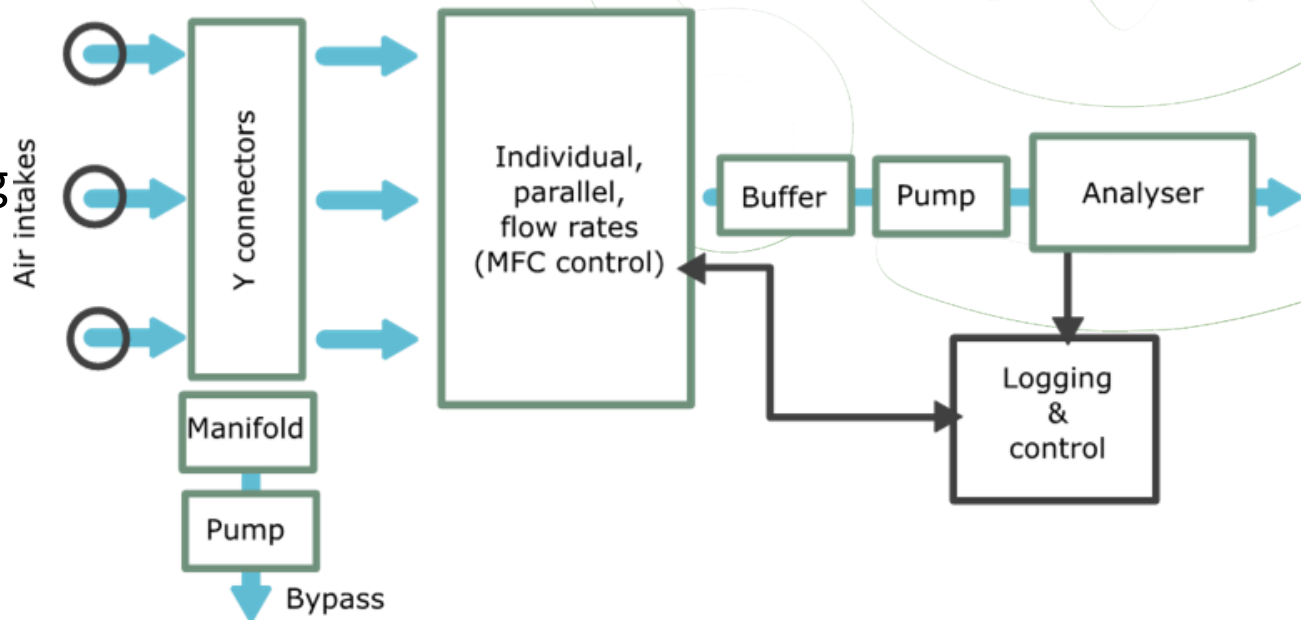

## 2. How to measure the storage term

### Sampling system

#### 3) Sequential sampling

**PRO:** easier set-up and control

**CONS:** more data processing

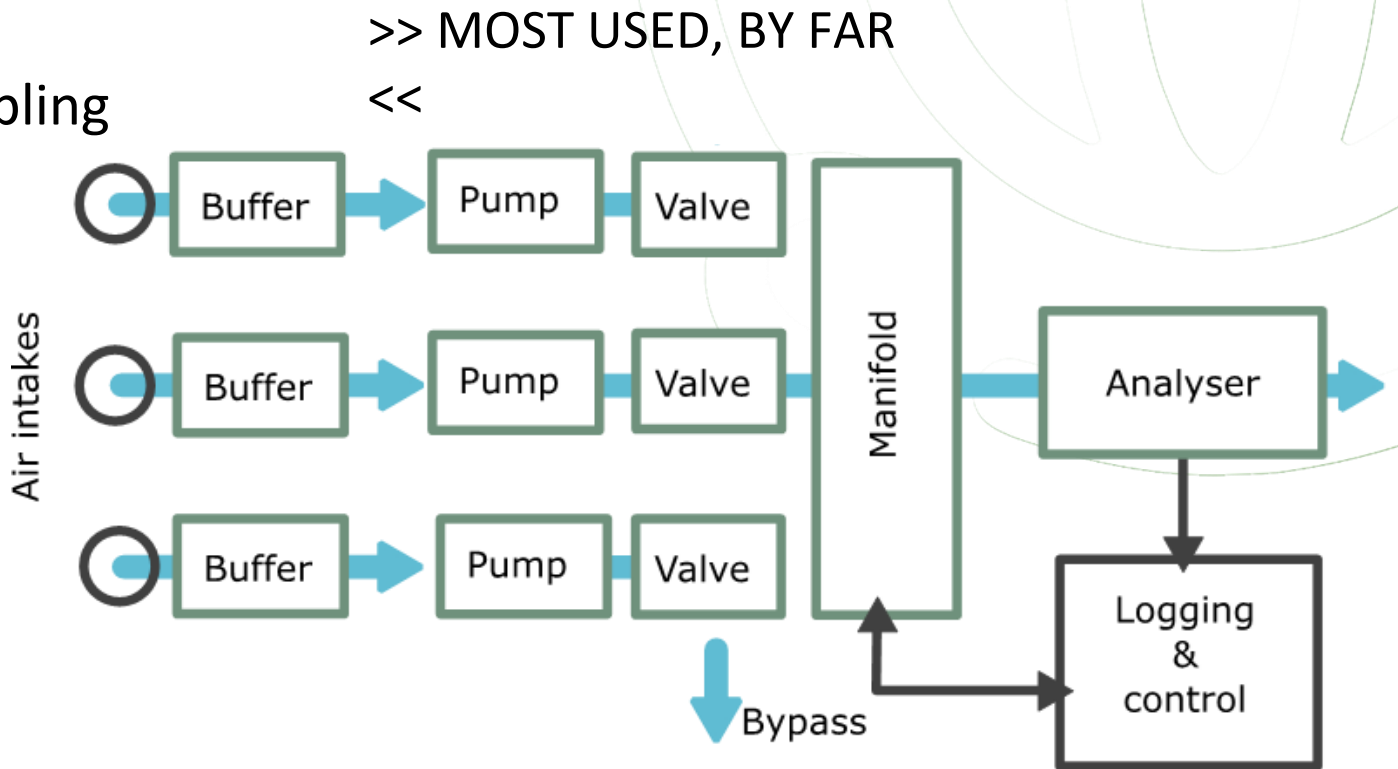

## 2. How to measure the storage term

### Sampling system: air inlets



## 2. How to measure the storage term

### Sampling system: air inlets



## 2. How to measure the storage term

### Sampling system: air line



## 2. How to measure the storage term

### Sampling system: vertical distribution of sampling points

- N levels

$$N_{\min} = ECh^a \quad \text{where } a \cong 0.67$$

e.g.  $ECh=6m \gg 3$  levels or  $ECh=35m \gg 10$  levels

- Level distribution

$$Zn_i = (n_i^b * h) * n^{-b}$$

where  $Zn_i$  = level height,  $n_i$  = level number,  $n$  = number of levels,  $b = 1.5$  [1 for linear distribution,  $e$  for logarithmic distribution]

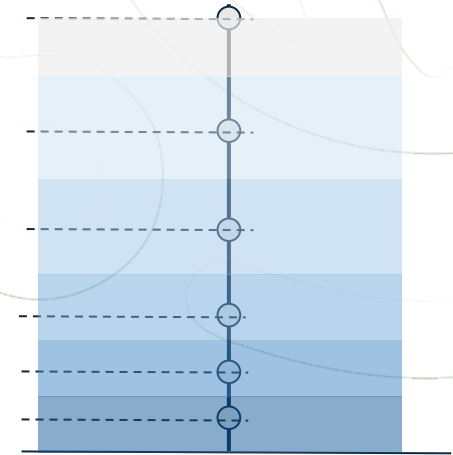

## 2. How to measure the storage term

### Sampling system

- *Theory*: gradient measurements should be instantaneous and simultaneous (ok “separate” and “simultaneous” systems)
- “Sequential” a full measurement cycle between 60 and 300 s
- Each inlet sampled for  $X$  s according to air traveling time (only a few s are needed for avg)
- Measurements/averaging: across the end of a half-hour and the beginning of the next one

### 3. How to calculate the storage term

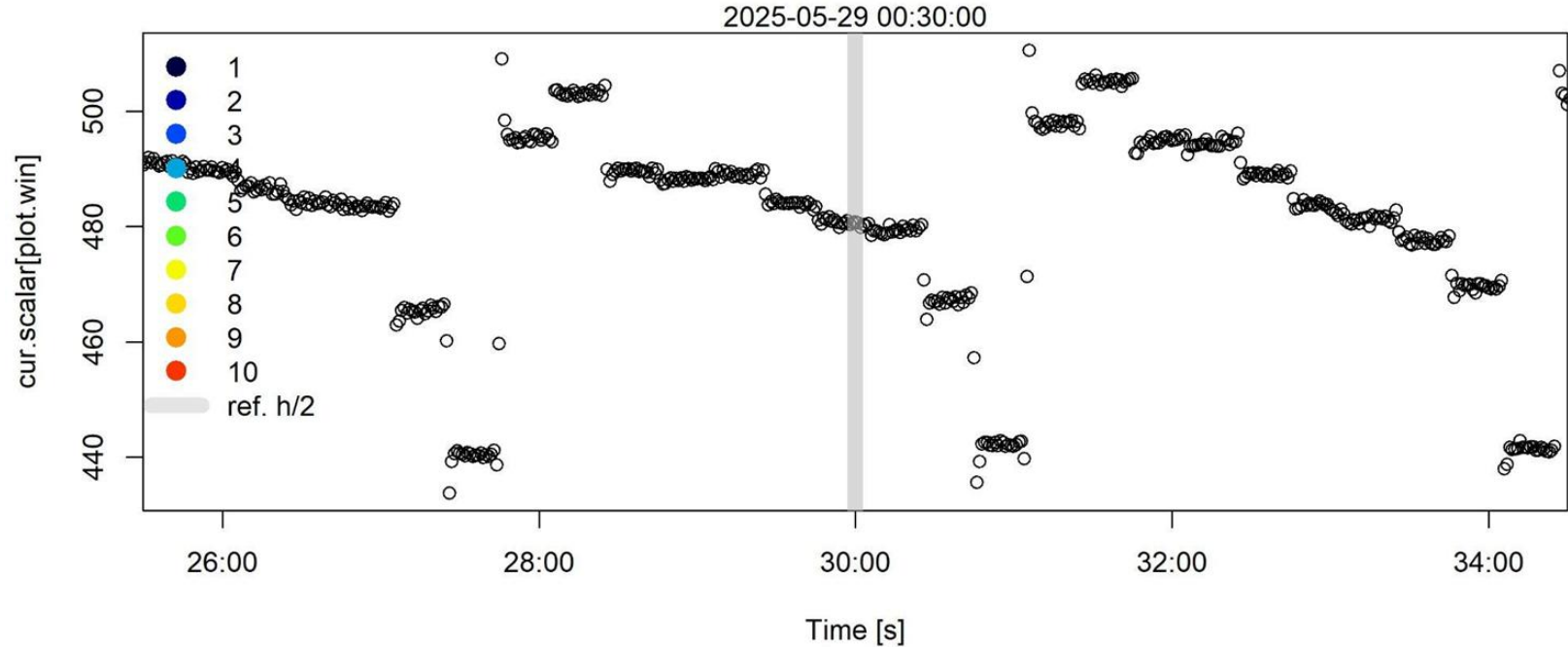

### 3. How to calculate the storage term

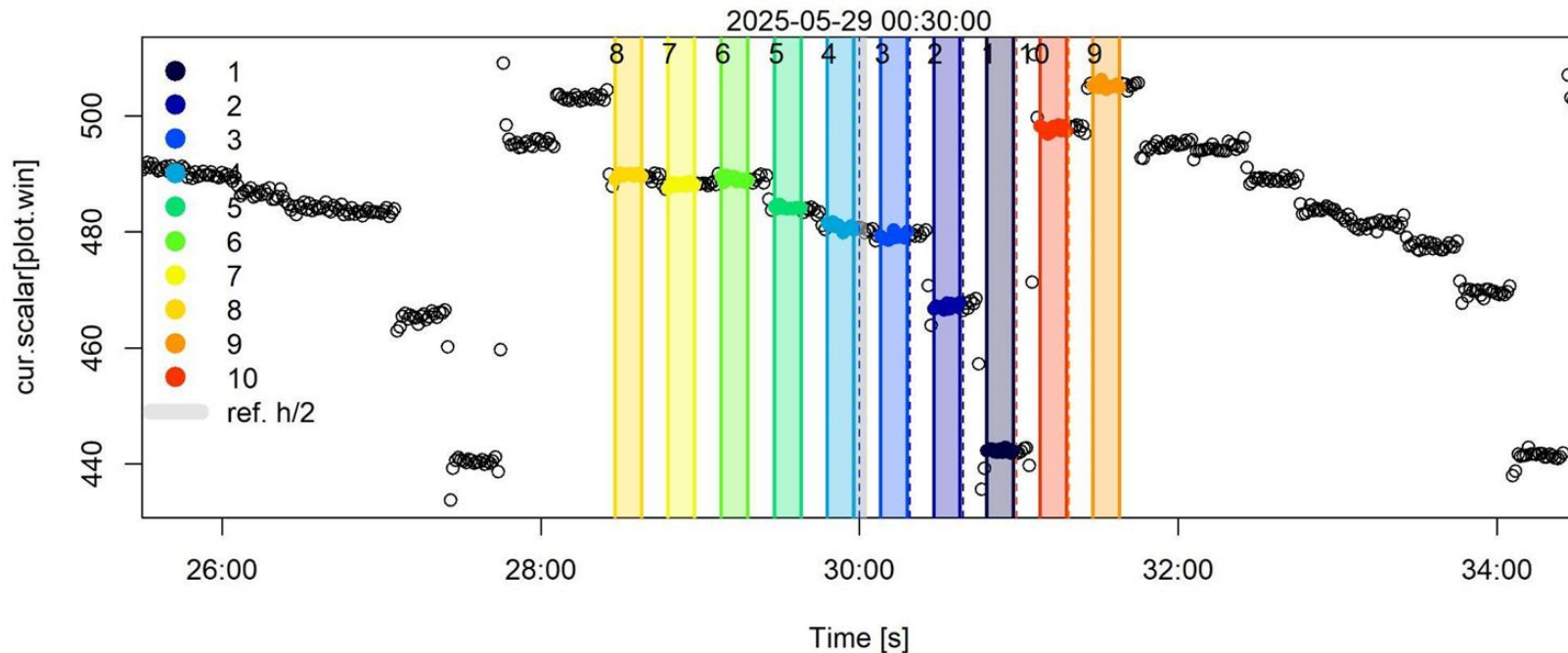

### 3. How to calculate the storage term

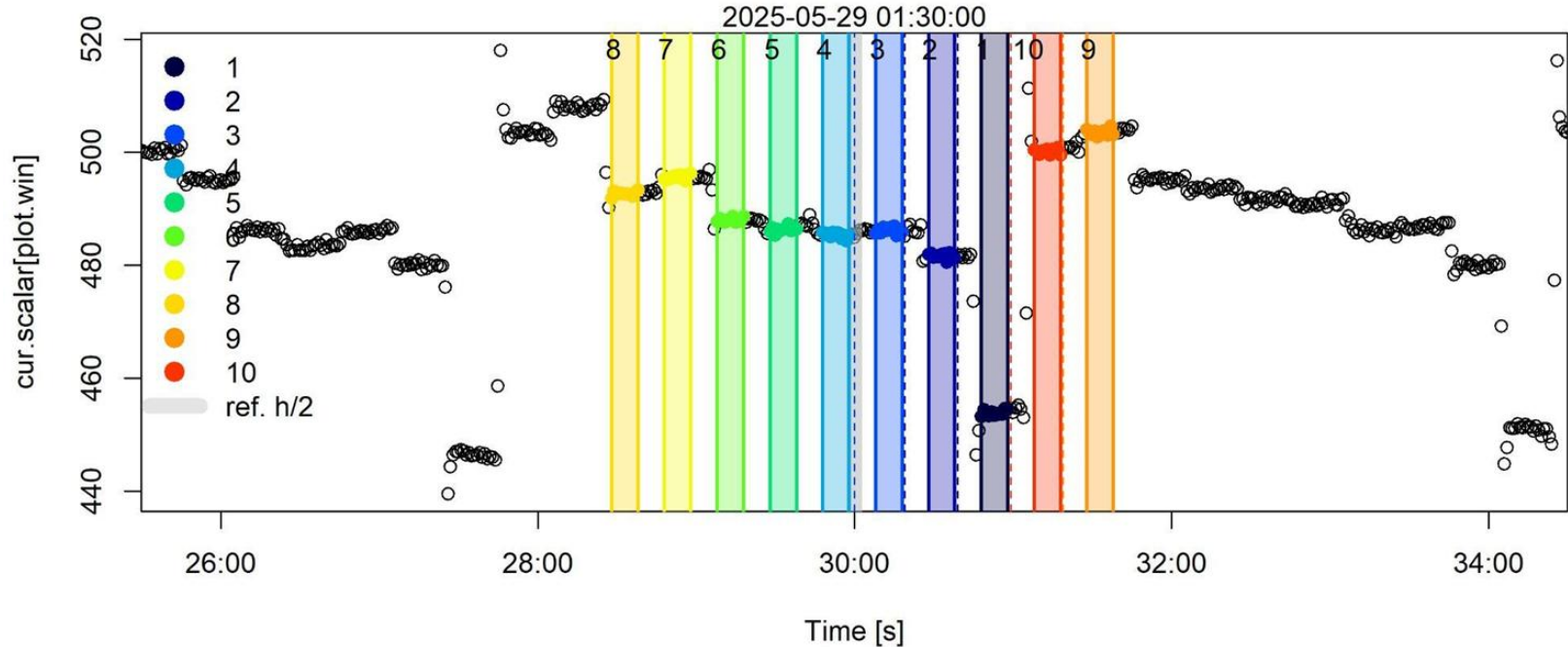

### 3. How to calculate the storage term

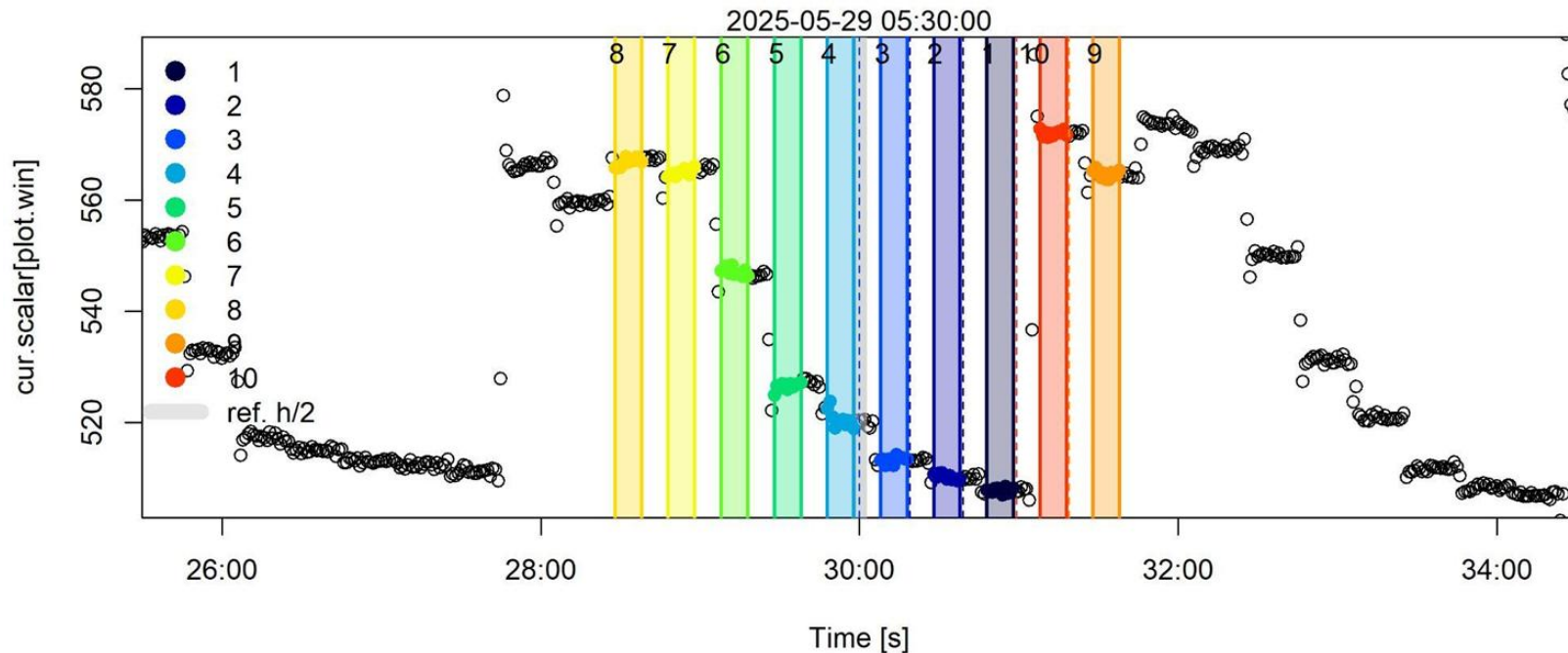

### 3. How to calculate the storage term

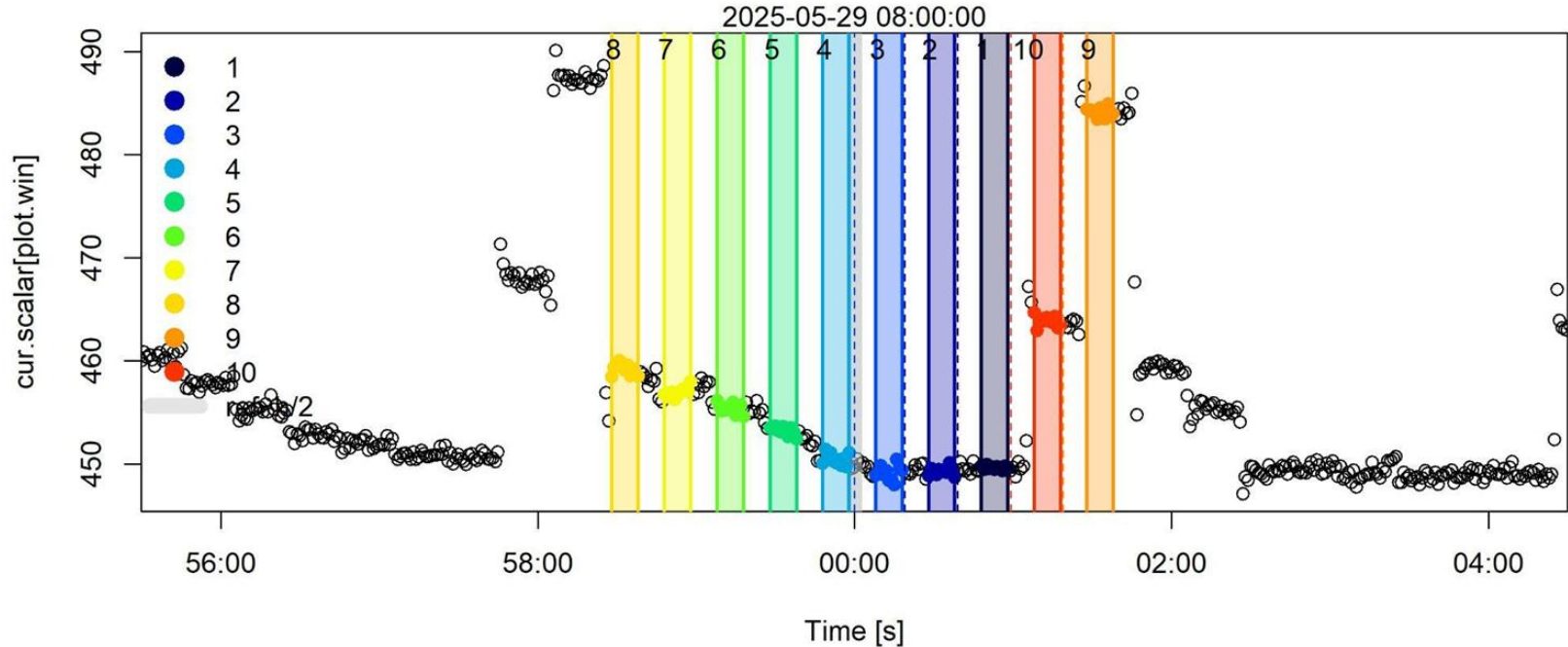

### 3. How to calculate the storage term

$$SC \cong \overline{\rho_d}(z) \sum_{i=1}^{i=n} \frac{\Delta \bar{c}(z_i)}{\Delta t} \Delta z_i$$

$\overline{\rho_d}$  is air molar density calculated as a function of air moisture, temperature and pressure

$\Delta \bar{c}$  is the gas molar fraction difference at height  $z_i$  over the time period  $\Delta t$  (i.e. 1800 s)

$\Delta z_i$  is the vertical extent of the corresponding  $i^{\text{th}}$  air layer

## 4. Profile and storage flux dynamics

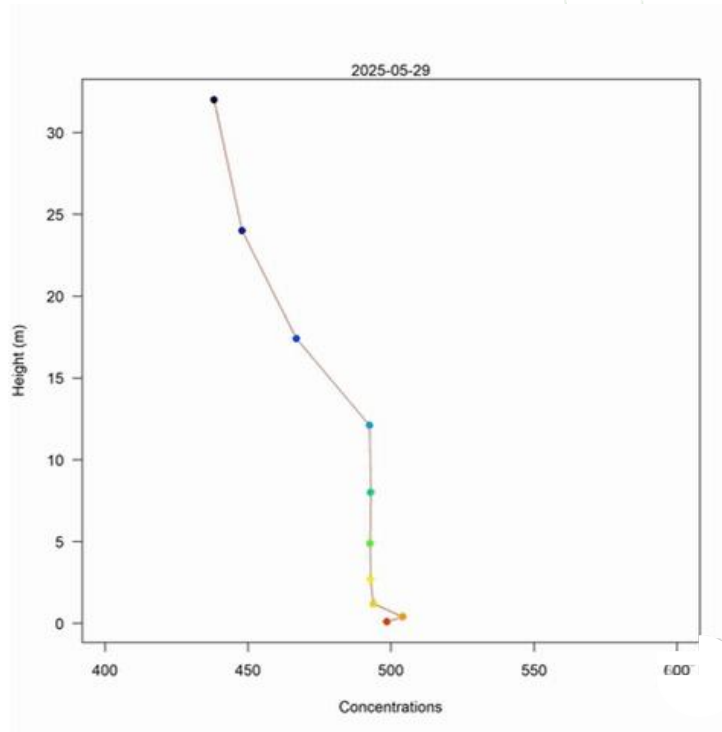

# 4. Profile and storage flux dynamics

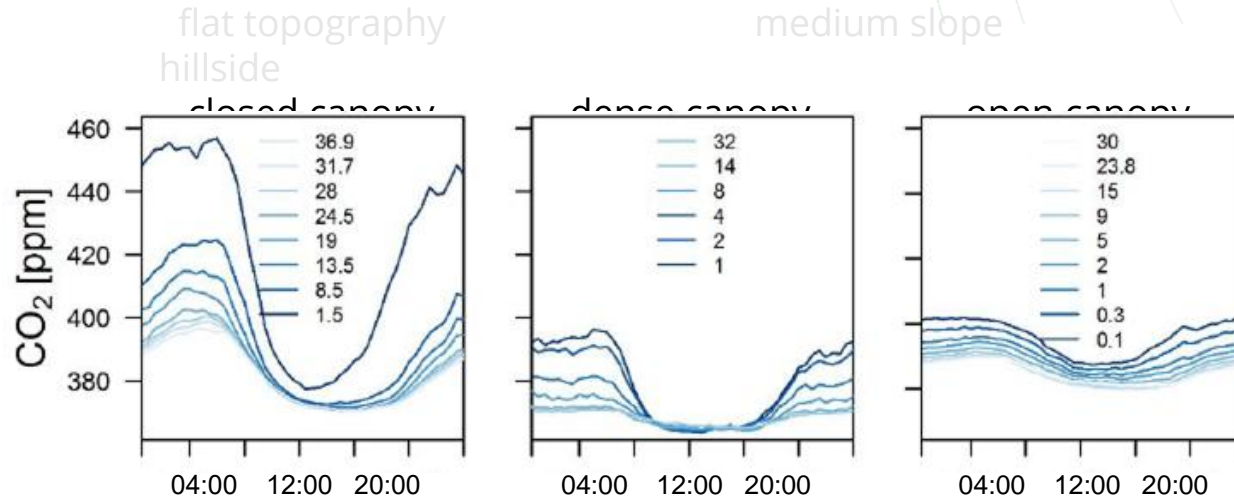

# 4. Profile and storage flux dynamics

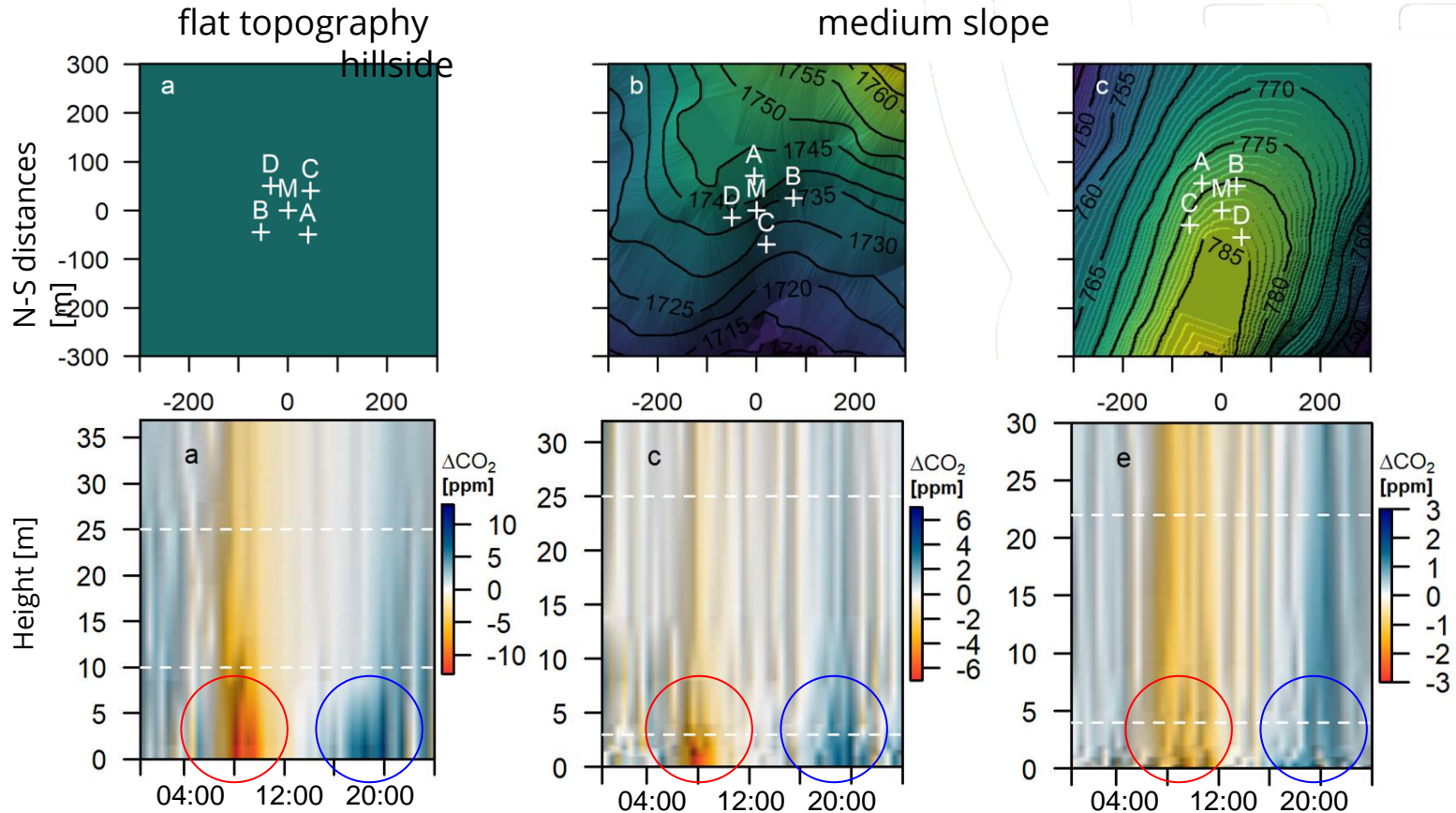

## 4. Profile and storage flux dynamics

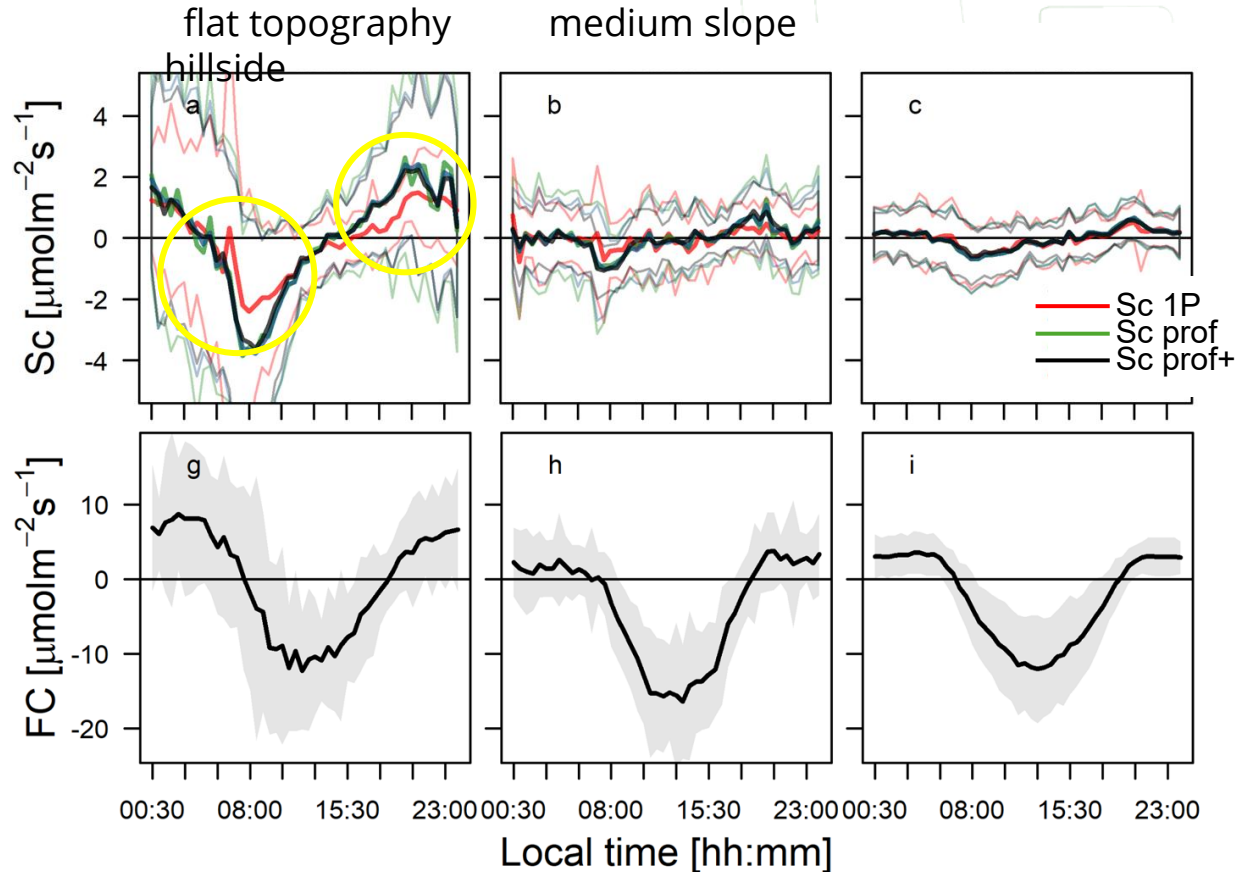

## 4. Profile and storage flux dynamics

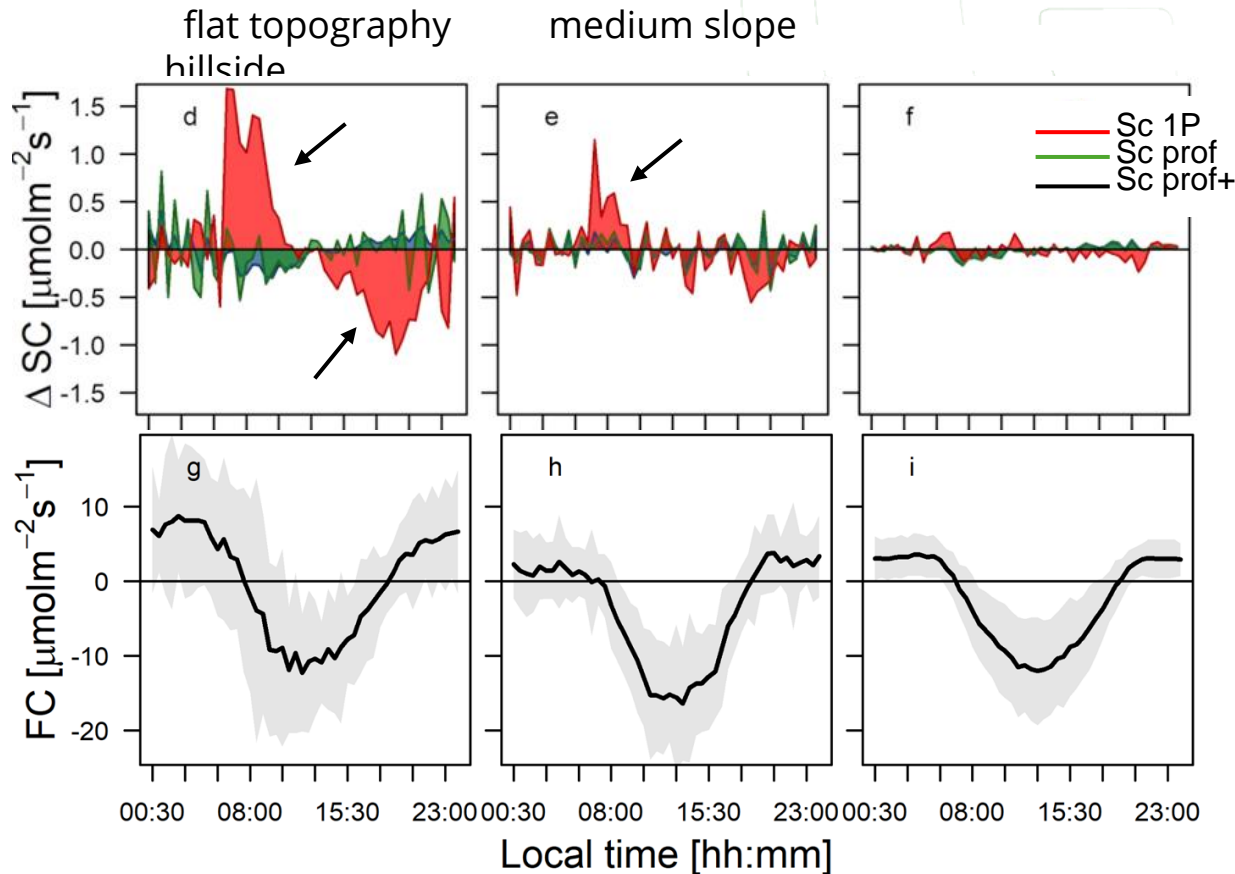

## 4. Key points

Which are the main points to consider?

- Not only needed for forest! Consider a profile system if  $ECh > 2$  m
- Levels number adequate to the EC measuring height
- Levels distribution adequate to the canopy structure
- Try sampling the horizontal variability the most
- Cycling time: consider  $< 300$  s (10-15 s of stable [c] are enough)
- Leakage tests and maintenance
- Schedule GA field check and calibrations
- Do not forget the TA-RH profile!



# THANKS!

**IR0000032 – ITINERIS, Italian Integrated Environmental Research Infrastructures System**  
(D.D. n. 130/2022 - CUP B53C22002150006) Funded by EU - Next Generation EU PNRR-  
Mission 4 "Education and Research" - Component 2: "From research to business" - Investment  
3.1: "Fund for the realisation of an integrated system of research and innovation infrastructures"



Finanziato  
dall'Unione europea  
NextGenerationEU



Ministero  
dell'Università  
e della Ricerca



# Let's calculate it

