



Training event “Atmospheric standardized observations: Methods and maintenance in observatories – In-Situ.”

Aerosol optical properties

Valeria Mardoñez – v.mardonez@isac.cnr.it

Laura Renzi – laura.renzi@cnr.it

Marco Zanatta – marco.zanatta@cnr.it

IR0000032 – ITINERIS, Italian Integrated Environmental Research Infrastructures System
(D.D. n. 130/2022 - CUP B53C22002150006) Funded by EU - Next Generation EU PNRR-
Mission 4 “Education and Research” - Component 2: “From research to business” - Investment
3.1: “Fund for the realisation of an integrated system of research and innovation infrastructures”



Why optical properties are important?

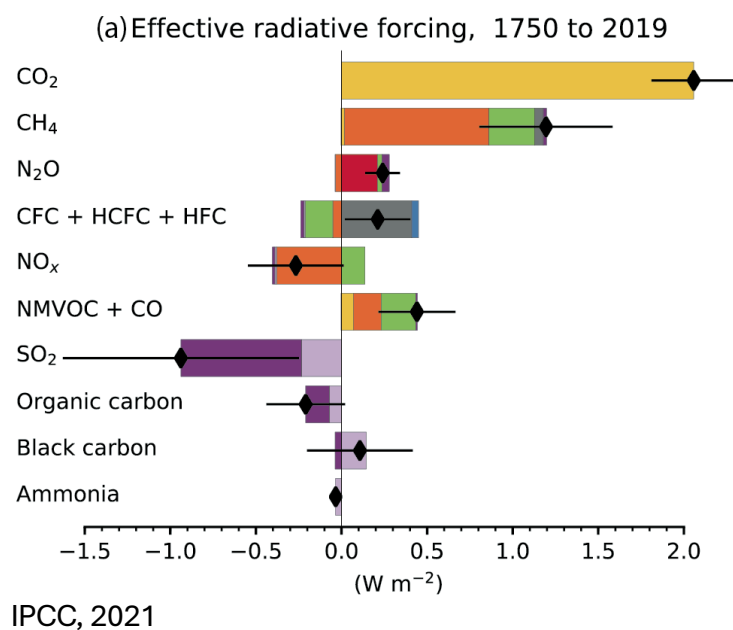

Despite being very small, aerosols constitute an important climate forcing agent.

To be able to estimate their impact on climate, reliable and standardized global observations are needed



ACTRIS seeks to facilitate the integration of the research community in producing high-quality open access data on atmospheric constituents

Aerosol – light interactions

Extensive physical parameters:

- **Absorption coefficient** (b_{abs} [Mm^{-1}])
- **Scattering coefficient** (b_{sca} [Mm^{-1}])

These parameters are proportional to the amount of particles present in the atmosphere

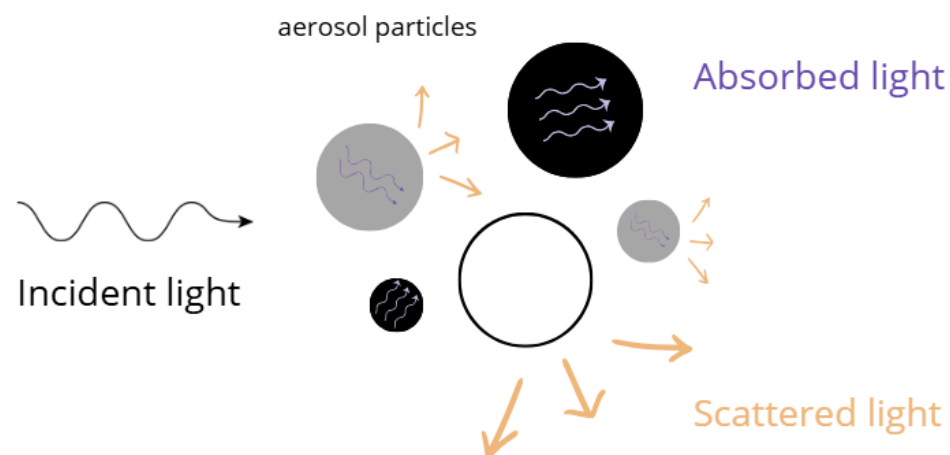

$$b_{ext}(\lambda) = b_{abs}(\lambda) + b_{sca}(\lambda)$$

The intensity of these interactions is a function of wavelength

Aerosol – light interactions

$$b_{ext}(\lambda) = b_{abs}(\lambda) + b_{sca}(\lambda)$$

$$SSA(\lambda) = b_{sca}(\lambda)/b_{ext}(\lambda)$$

Sea salt
Dominant scattering



Black carbon
Dominant absorption



~1 ← SSA → ~0

Aerosol – light interactions

Absorption coefficient b_{abs}

Scattering coefficient b_{sca}

Single scattering albedo SSA

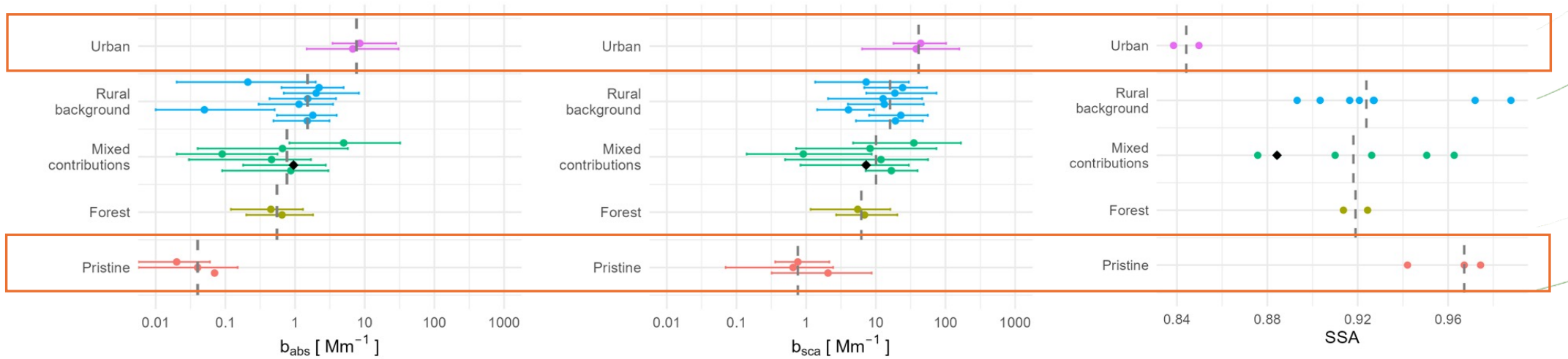

- Worldwide median values for 2016 (Extracted from Laj et al., 2020)
- ◆ Monte Cimone (2020-2022)
- Median of the displayed median values

Wavelength dependence

$$b_{abs}(\lambda) \propto \lambda^{-AAE}$$

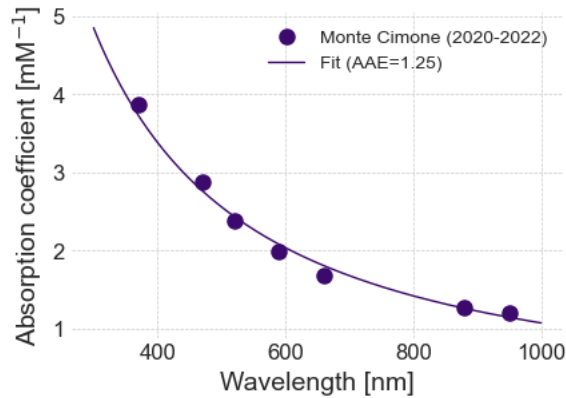

>2 ← AAE → ~1



Dust
Absorption mainly
at short wavelengths



BC
Efficient absorption
at all wavelengths



$$b_{sca}(\lambda) \propto \lambda^{-SAE}$$

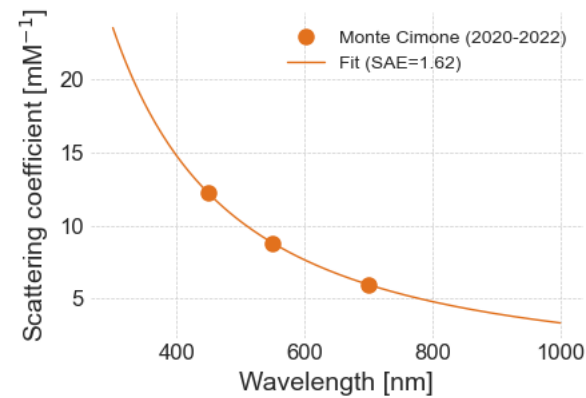

~< 0 ← SAE → >2

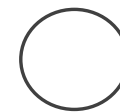
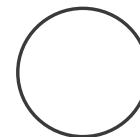

Bigger particles

Smaller particles

Measuring aerosol optical properties in ACTRIS

- Measurements are conducted at **ACTRIS observational platforms** (e.g., Monte Cimone)
- To qualify as a **National Facility**, a site must undergo a **labeling procedure**
- The **Leibniz Institute for Tropospheric Research (TROPOS)** oversees aerosol instrument compliance and calibration
- **Topical Centers** also:
 - Provide **periodic calibrations**
 - Organize **workshops and training**
 - Support data quality across the network



Measuring aerosol optical properties in ACTRIS

Scattering and back-scattering coefficients

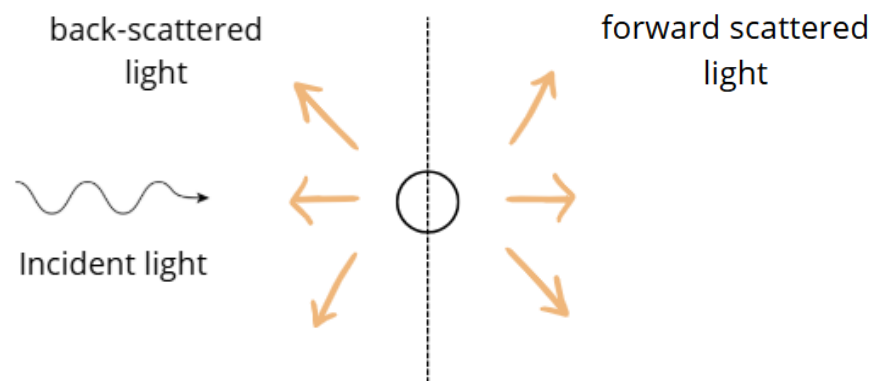

Scattering pattern depends on particle Size

- **Large particles** (e.g., dust, clouds):
Scattering is **less symmetrical** (mainly forward scattering)
- **Small particles** (e.g., smoke):
Scattering is **more symmetrical** in forward and backward directions

Measuring aerosol optical properties in ACTRIS

Scattering and backscattering coefficients

The recommended instrument for measuring the **total scattering and back-scattering coefficients** is the **multi-wavelength Integrating Nephelometer**

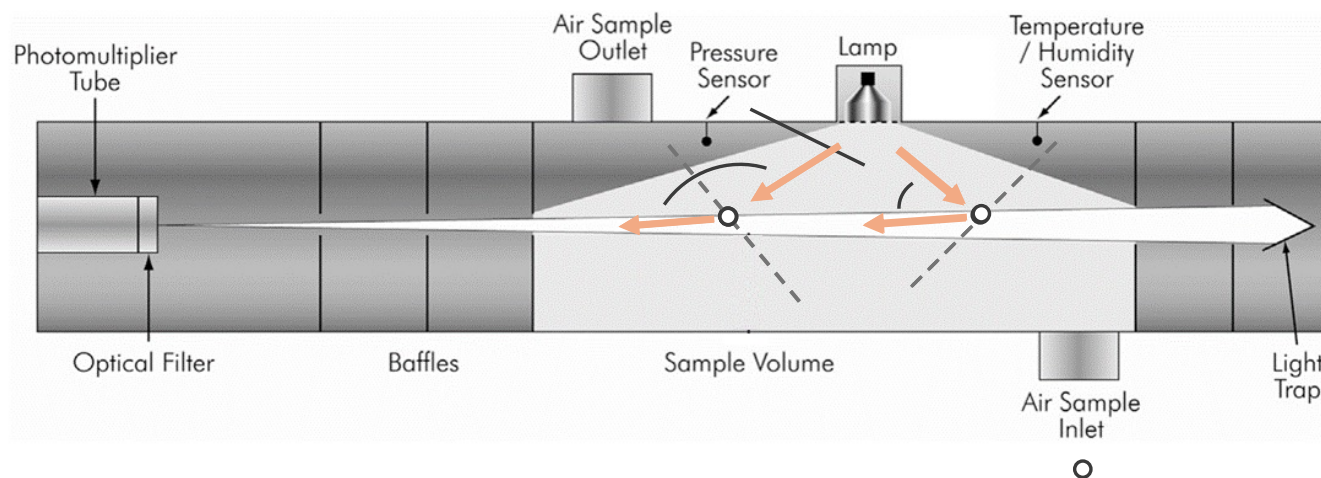

Measuring aerosol optical properties in ACTRIS

Scattering and back-scattering coefficients

Instrument type: Integrating Nephelometer

TSI:

- 3563 (old model; calibration provided by CAIS-ECAC until end of 2025)

Acoem (Ecotech):

- Aurora 4000 (old model; calibration provided by CAIS-ECAC)
- Aurora 3000 (old model; calibration provided by CAIS-ECAC)
- **Aurora NE-400 polar (current model; calibration provided by CAIS-ECAC)**
- **Aurora NE-300 (current model; calibration provided by CAIS-ECAC)**



Measuring aerosol optical properties in ACTRIS

Absorption coefficient

Extinction – scattering:

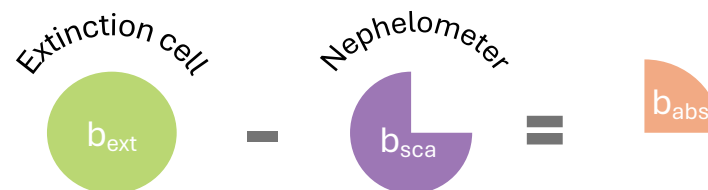
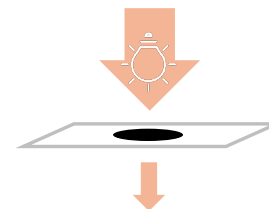

Photo-acoustic absorption photometers:



Filter based absorption photometers:



How to measure optical properties in ACTRIS

Absorption coefficients

Instrument type: Filter based absorption photometer

Thermo Scientific:

- MAAP 5012 (old model; calibration provided by CAIS-ECAC)

Aerosol Magee Scientific:

- Aethalometer AE31 (old model; calibration provided by CAIS-ECAC until end of 2025)
- **Aethalometer AE33/43 (current model; calibration provided by CAIS-ECAC)**
- **Aethalometer AE36/AE36s (current model; calibration provided by CAIS-ECAC)**

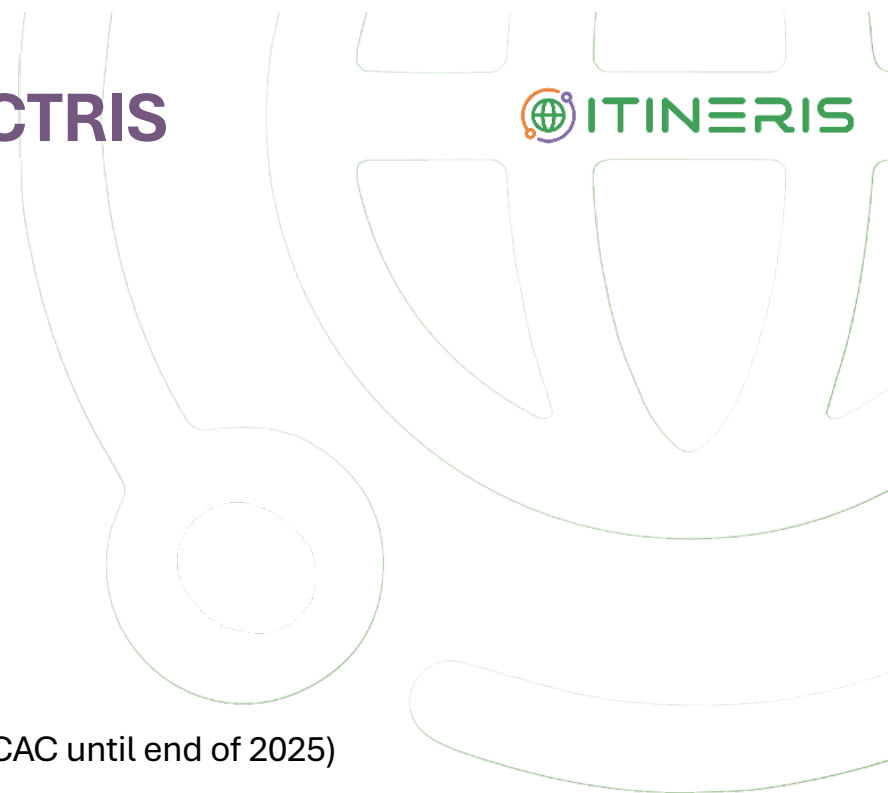

How to measure optical properties in ACTRIS

Absorption coefficient

Multi Angle Absorption Photometer (MAAP)

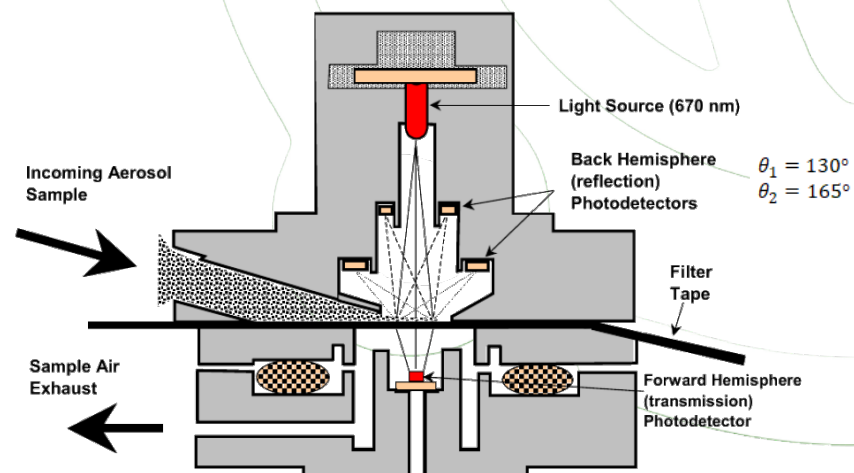

$$b_{abs}(670 \text{ nm}) = b_{atn}(670 \text{ nm}) - f(b_{sca}(670 \text{ nm}))$$

↳ Mie theory

How to measure optical properties in ACTRIS

Absorption coefficient

Aethalometer



7λ : 370, 470, 520, 590, 660, 880, 950 [nm]

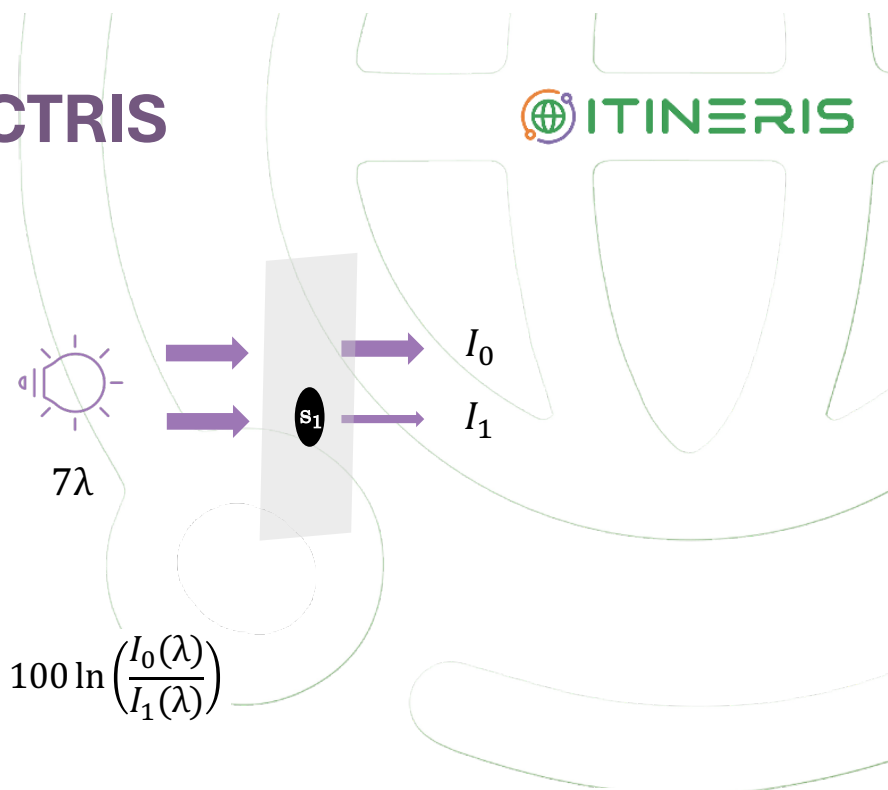

$$ATN_t(\lambda) = 100 \ln \left(\frac{I_0(\lambda)}{I_1(\lambda)} \right)$$

$$b_{atn}(\lambda) = \frac{A \cdot \Delta ATN(\Delta t)}{100 \cdot Q \cdot \Delta t}$$

$$b_{abs}(\lambda) = \frac{b_{atn}(\lambda)}{C_0}$$

A: spot area
Q: flow rate
 Δt : time resolution

C_0 : Multiple scattering correction factor

Mass absorption cross section (MAC)

The aethalometer measures the **absorption coefficient** of the aerosol particles. However, it reports the **equivalent mass concentration of black carbon (eBC)**, the main light-absorbing aerosol in the atmosphere

$$eBC = \frac{b_{abs}(\lambda)}{MAC(\lambda)}$$

MAC: Absorption efficiency per unit of mass [m^2g^{-1}]

Aethalometer



10.35 m^2g^{-1} (660nm)
7.77 m^2g^{-1} (880nm)



Experimental average



10 m^2g^{-1} (637nm)
10.6 m^2g^{-1} (637nm)
7.8 m^2g^{-1} (880nm)



Experimental variability



~ 7- ~20 m^2g^{-1} (637nm)

Zanatta et al, 2016
Savadkoohi et al., 2024

Standard Operation Procedures (SOP)



	Nephelometer	MAAP	Aethalometer
Time resolution	1 min	1 min	1 min
Flow rate (after dryer)	5 L min ⁻¹ (STP)	16.67 L min ⁻¹	5 L min ⁻¹ (STP)
External pump	Recommended	Recommended	---
Measured atmospheric conditions	T, P, RH	T, P	---

Additional general recommendations for aerosol sampling:

Tubbing: Black tube/ stainless steel

Dryer at the inlet

STP: 273.15 K and 1013 hPa

Maintenance (general recommendations)



Frequent (1-3 months)

- Regular **zero** checks
- Regular **flow** checks/calibrations
- Check measurements are performed at **RH < 40%**
- Check **insect** traps
- Check and clean filter fans
- Check recording time

When required (Instrument manual)

- Leak test (~6 months)
- Cell cleaning (~6 months)
- Calibration center

Take detailed notes on a logbook

Maintenance

Nephelometer

- Regular span checks (every 3 months):

- CO₂ (>99.9%)** (20 min to 1 h):

- Deviation < |± 5%|

- Internal zero (at least once a day):

- 2 Mm⁻¹ < zero < 2 Mm⁻¹

- flow < |± 20%|

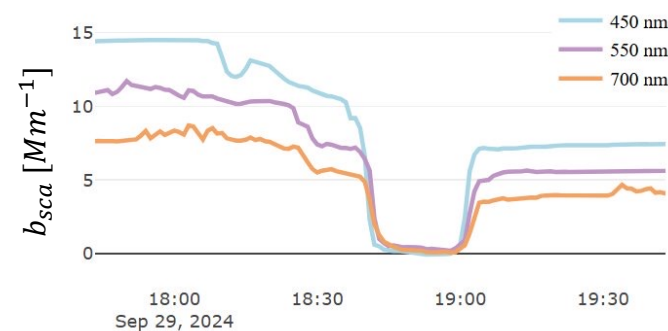
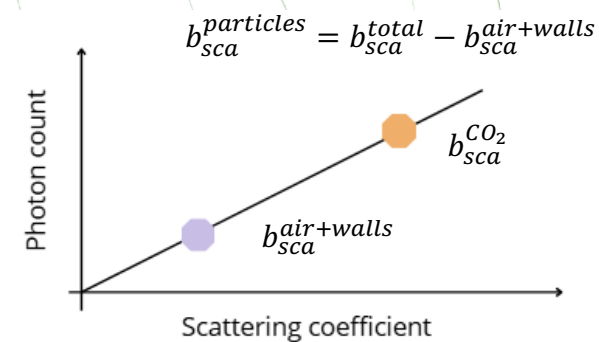

Measurement corrections

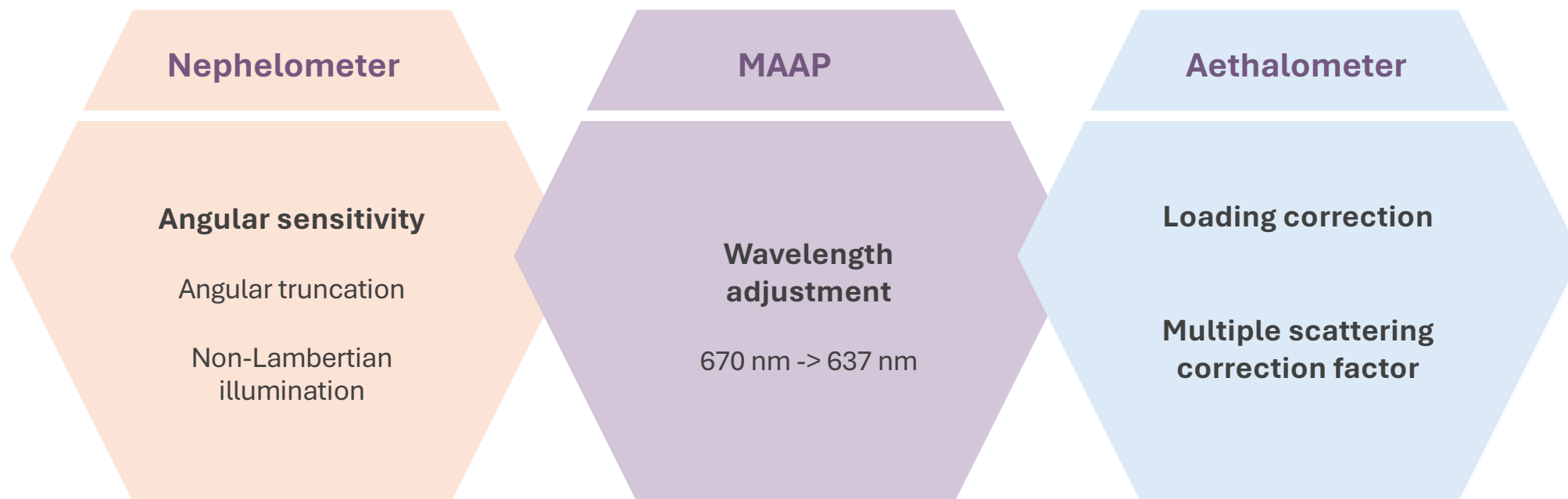

Measurement corrections

Nephelometer

Angular sensitivity

Angular truncation

Non-Lambertian illumination

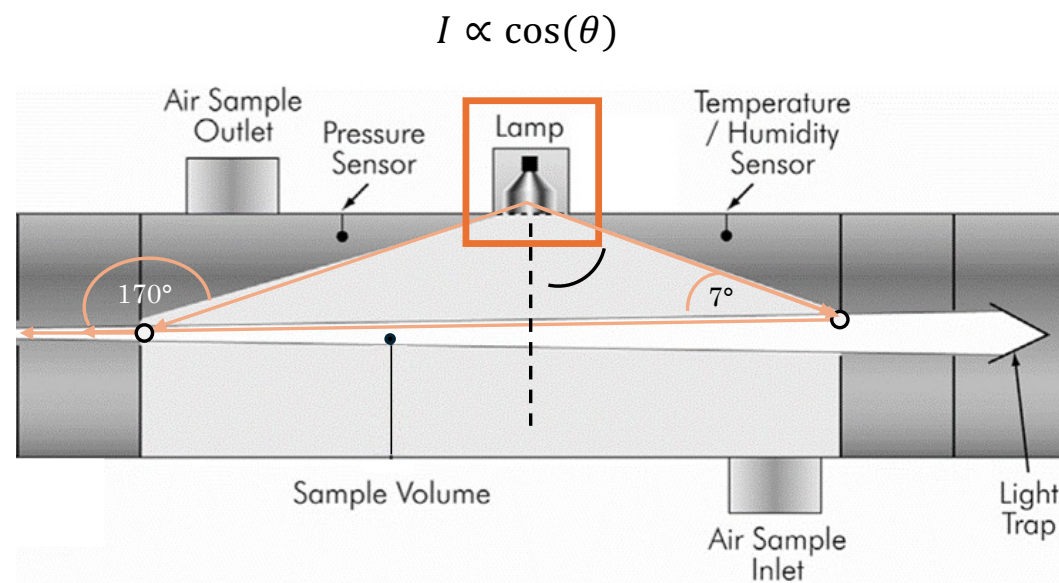

Done according to Müller et al., 2011

Measurement corrections

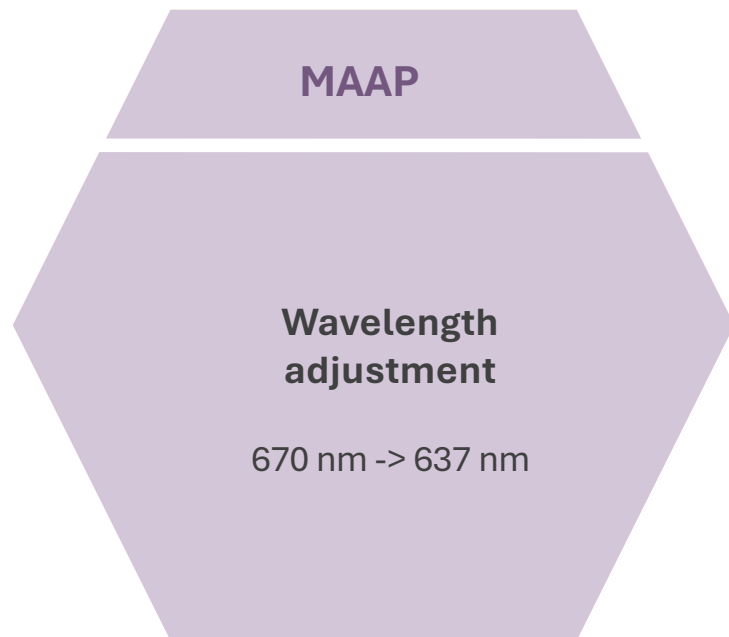

ITINERIS

$$b_{abs}' = 1.05 \cdot b_{abs,0}$$

The background of the right side of the slide features a green line-art pattern of a globe and several curved lines. The ITINERIS logo is positioned in the upper right area.

Measurement corrections

Aethalometer

Loading correction

- Algorithms post processing (Coen et al., 2010)
- Internal correction (Drinovec et al., 2015)

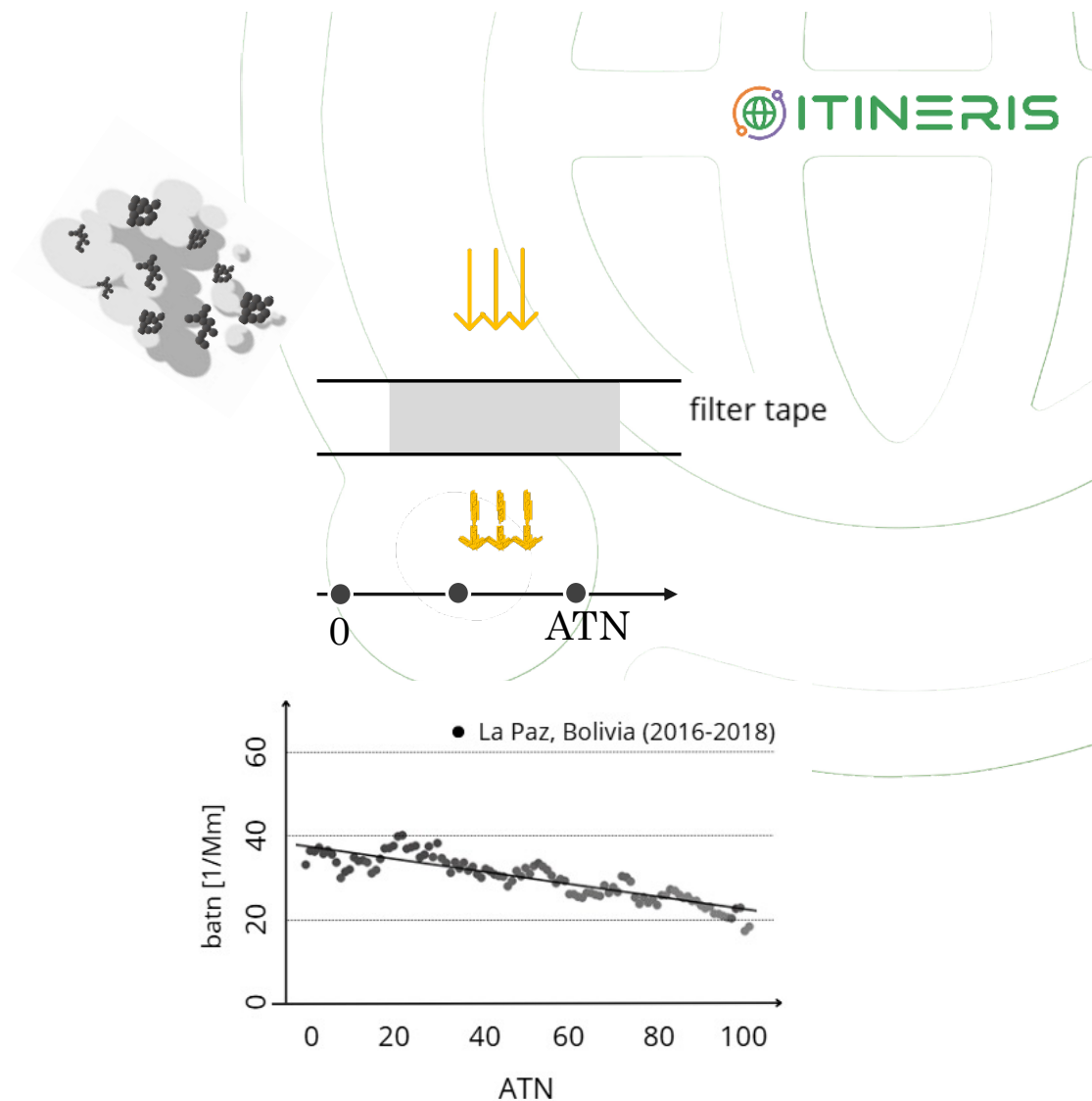

Measurement corrections

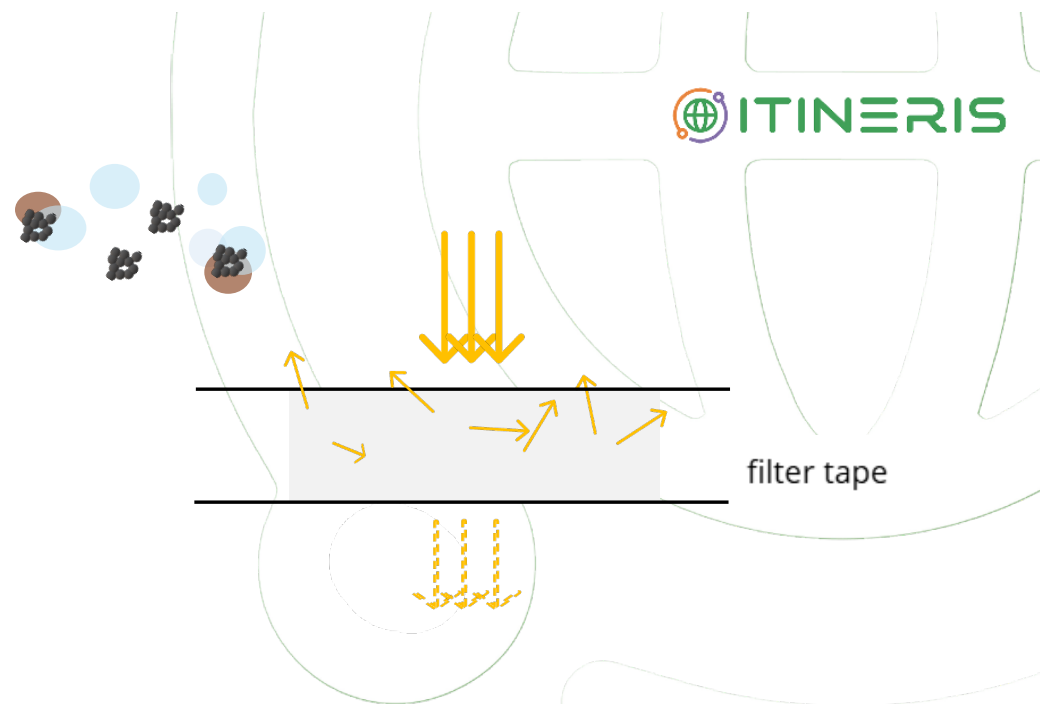
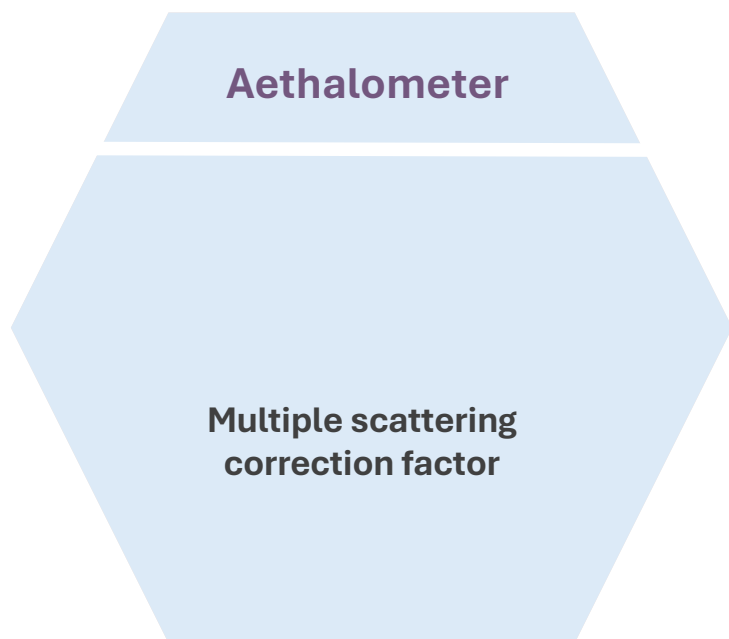

$$b_{abs,0}(\lambda) = \frac{b_{atn}(\lambda)}{C_0}$$

$$b'_{abs}(\lambda) = \frac{b_{atn}(\lambda)}{\cancel{C_0}} \cdot \boxed{\frac{\cancel{C_0}}{C'}} = \frac{b_{abs,0}(\lambda)}{H}$$

C_0 : 1.39 (AE33)

C' : 2.44 (AE33)

H : 1.76 (AE33)

Example from real life in Cimone

Submitting absorption coefficient to EBAS data portal

Filter based absorption photometer: **Multi Angle Absorption Photometer (MAAP)**

Data reduction following “*Guidelines for Manual QC of MAAP data*”



(T. Muller and M. Fiebig)

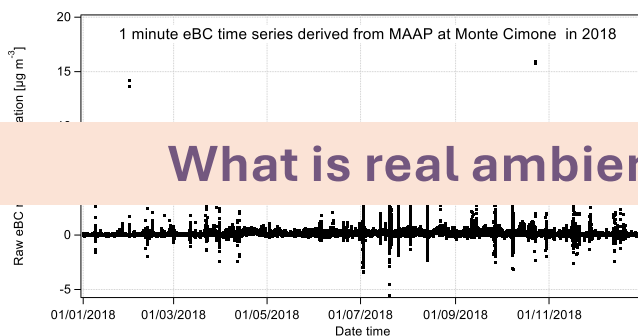

What is real ambient variability and what not?

Example from real life in Cimone

Submitting absorption coefficient to EBAS data portal

Level 0

- **Time stamp = 1 min**
- **eBC mass conc.**
- **Flagging**
 - Flow stability
 - Signal to LOD
 - Signal spread

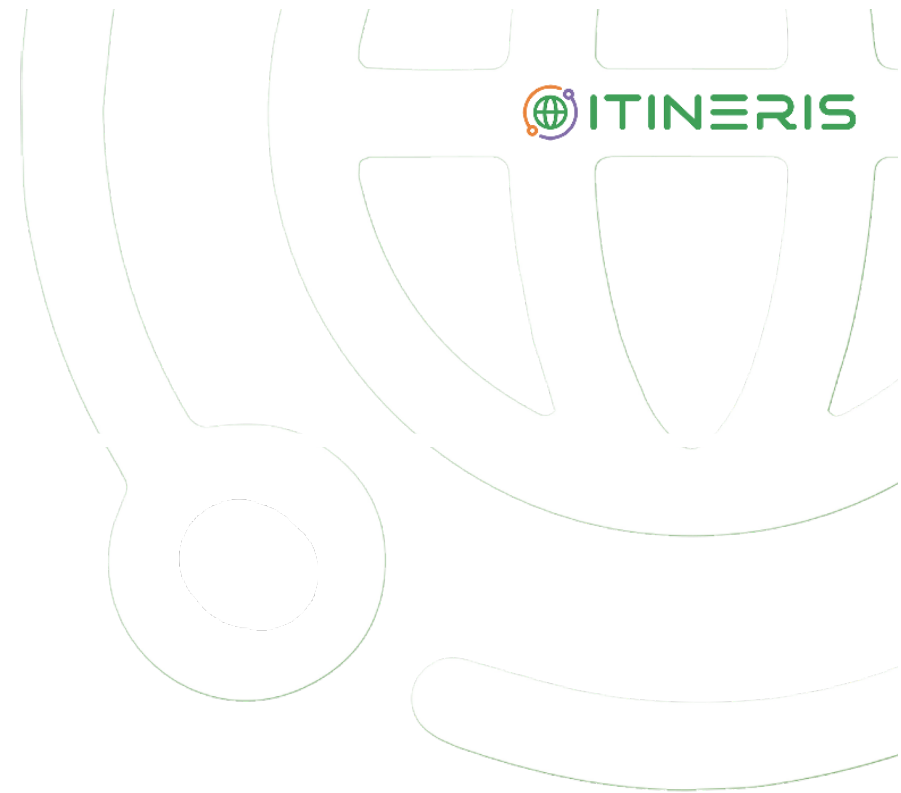

Example from real life in Cimone

Submitting absorption coefficient to EBAS data portal

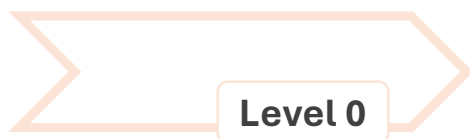

- **Time stamp = 1 min**
- **eBC mass conc.**
- **Flagging**
 - Flow stability
 - Signal to LOD
 - Signal spread

○ Raw data ● Valid data

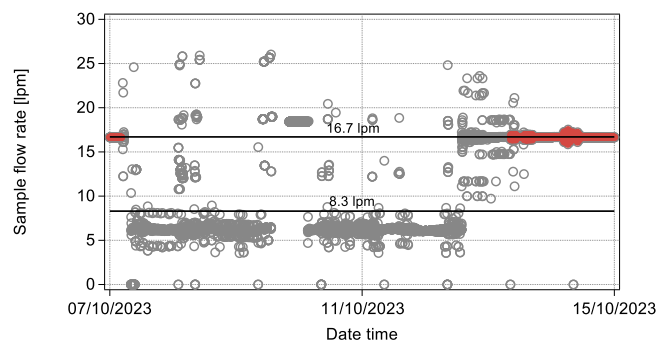

REQUIREMENTS

Flow higher than 8.3 lpm

Flow = SetPoint \pm 5%

Example from real life in Cimone

Submitting absorption coefficient to EBAS data portal

Level 0

- Time stamp = 1 min
- eBC mass conc.
- Flagging
 - Flow stability
 - Signal to LOD
 - Signal spread

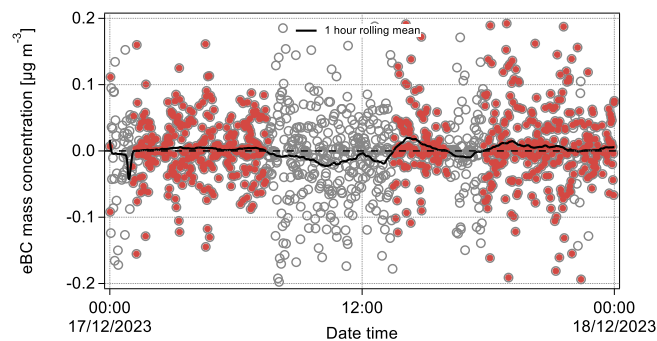

○ Raw data ● Valid data

REQUIREMENTS

1 h running mean > LOD

Example from real life in Cimone

Submitting absorption coefficient to EBAS data portal

○ Raw data ● Valid data

Level 0

- Time stamp = 1 min
- eBC mass conc.
- Flagging
 - Flow stability
 - Signal to LOD
 - Signal spread

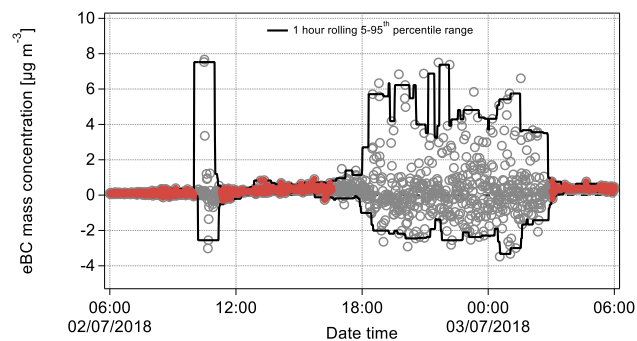

REQUIREMENTS

Low percentile > LOD

Percentile difference < $1 \mu\text{g m}^{-3}$

Example from real life in Cimone

Submitting absorption coefficient to EBAS data portal

Level 0

- Time stamp = 1 min
- eBC mass conc.
- Flagging
 - Flow stability
 - Signal to LOD
 - Signal spread

Contribution to invalid data

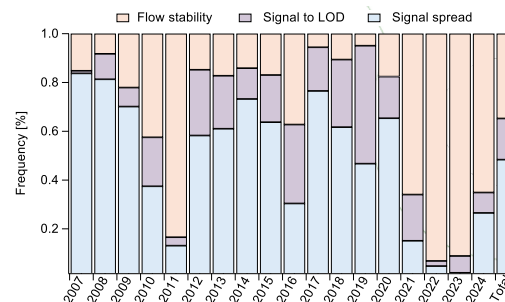

STATION AND INSTRUMENT SPECIFIC

Example from real life in Cimone

Submitting absorption coefficient to EBAS data portal

Level 1

- Time stamp = 1 min
- eBC → Abs coef. (σ_{ab670})
 - MAC : $6.6 \text{ m}^2 \text{ g}^{-1}$
- λ correction to 637 nm
 - $\sigma_{ab637} = \sigma_{ab670} * 1.05$
- Adjust to standard
 - Pressure
 - Temperature

REQUIREMENTS

$T_s = 273.15\text{K}$, $P_s = 1013 \text{ hPa}$

Instrumental T and P in optical chamber

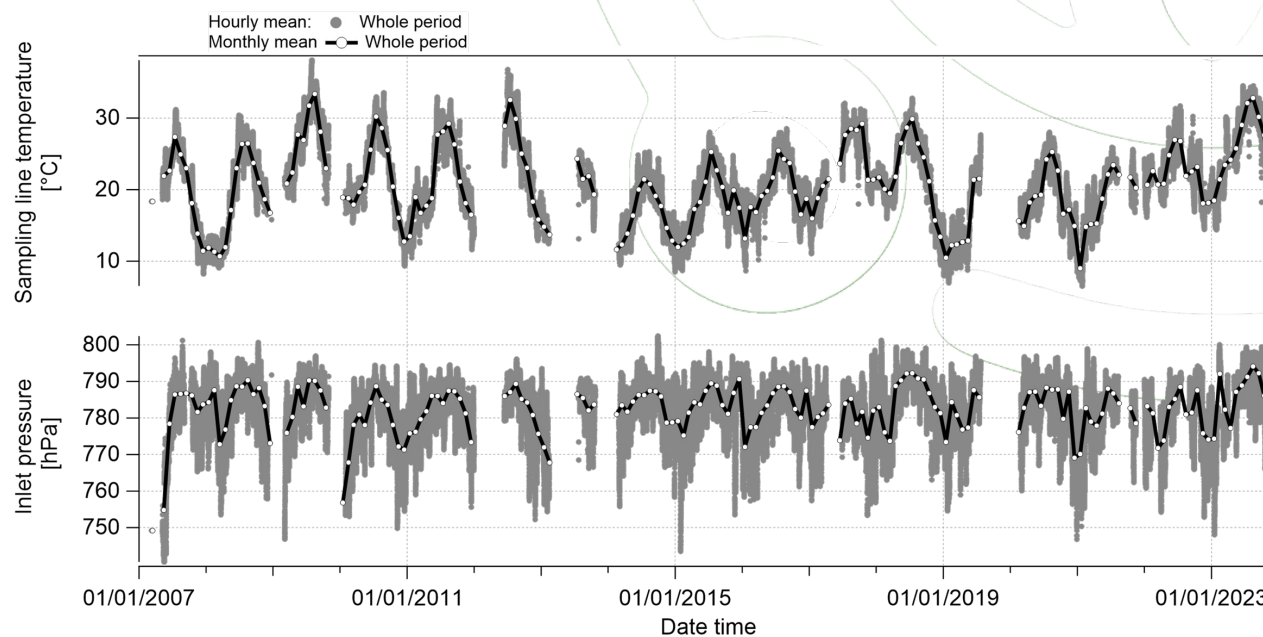

Example from real life in Cimone

Submitting absorption coefficient to EBAS data portal



Dwn = Downward inlet
 WAI-1 = Whole air inlet passive drying
 WAI-2 = Whole air inlet active drying

Level 1

- Time stamp = 1 min
- eBC → Abs coef. (σ_{ab670})
 - MAC : $6.6 \text{ m}^2 \text{ g}^{-1}$
- λ correction to 637 nm
 - $\sigma_{ab637} = \sigma_{ab670} * 1.05$
- Adjust to standard
 - Pressure
 - Temperature

REQUIREMENTS

$T_s = 273.15\text{K}$, $P_s = 1013 \text{ hPa}$

Instrumental T and P in optical chamber → Not always possible → Evolution of instruments and inlet

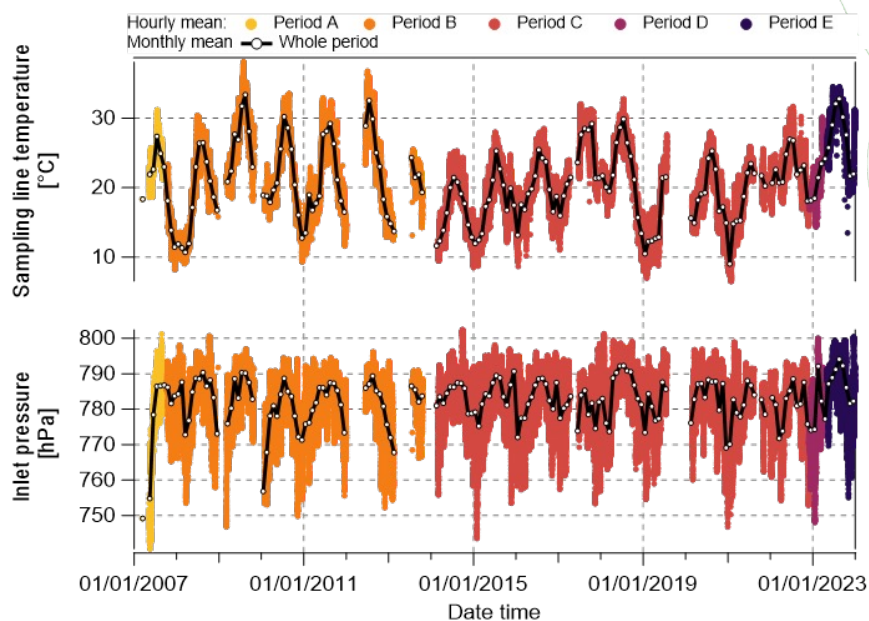

Year	Inlet	T-P measure
2007	Dwn	Neph M9003
2007-13	WAI-1	Neph M9003
2014-22	WAI	Neph TSI3565
2022-23	WAI-2	Neph TSI3565
2023-24	WAI-2	Neph AU3000
2024-	WAI-2	Line sonde

Example from real life in Cimone

Submitting absorption coefficient to EBAS data portal

Filter based absorption photometer: Multi Angle Absorption Photometer (MAAP)

Data reduction following “*Guidelines for Manual QC of MAAP data*”

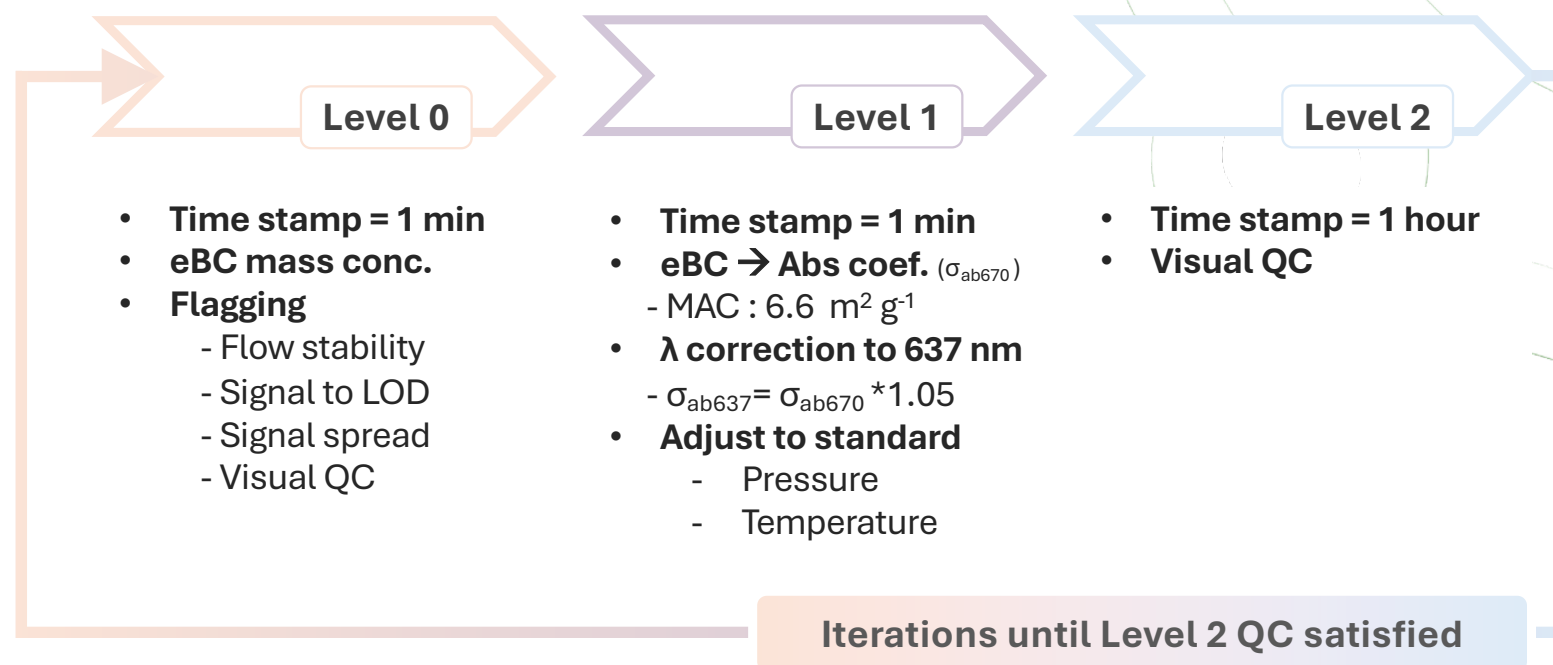



THANKS!

IR0000032 – ITINERIS, Italian Integrated Environmental Research Infrastructures System
(D.D. n. 130/2022 - CUP B53C22002150006) Funded by EU - Next Generation EU PNRR-
Mission 4 “Education and Research” - Component 2: “From research to business” - Investment
3.1: “Fund for the realisation of an integrated system of research and innovation infrastructures”



References

ACTRIS guidelines

<https://www.actris-ecac.eu/actris-gaw-recommendation-documents.html>

<https://www.actris-ecac.eu/particle-light-absorption.html>

<https://www.actris-ecac.eu/particle-light-scattering.html>

Filter-based absorption photometers

L. Drinovec *et al.*, “The ‘dual-spot’ Aethalometer: An improved measurement of aerosol black carbon with real-time loading compensation,” *Atmos Meas Tech*, vol. 8, no. 5, pp. 1965–1979, 2015, doi: 10.5194/amt-8-1965-2015.

T. Müller *et al.*, “Characterization and intercomparison of aerosol absorption photometers: Result of two intercomparison workshops,” *Atmos Meas Tech*, vol. 4, no. 2, pp. 245–268, 2011, doi: 10.5194/amt-4-245-2011.

A. Petzold *et al.*, “Recommendations for reporting black carbon measurements,” *Atmos Chem Phys*, vol. 13, no. 16, pp. 8365–8379, 2013, doi: 10.5194/acp-13-8365-2013.

M. Savadkoohi *et al.*, “Recommendations for reporting equivalent black carbon (eBC) mass concentrations based on long-term pan-European in-situ observations,” *Environ Int*, vol. 185, Mar. 2024, doi: 10.1016/j.envint.2024.108553.

References

A. Cuesta-Mosquera *et al.*, “Intercomparison and characterization of 23 Aethalometers under laboratory and ambient air conditions: Procedures and unit-to-unit variabilities,” *Atmos Meas Tech*, vol. 14, no. 4, pp. 3195–3216, 2021, doi: 10.5194/amt-14-3195-2021.

J. Yus-Díez *et al.*, “Determination of the multiple-scattering correction factor and its cross-sensitivity to scattering and wavelength dependence for different AE33 Aethalometer filter tapes: a multi-instrumental approach,” *Atmos Meas Tech*, vol. 14, no. 10, pp. 6335–6355, 2021, doi: 10.5194/amt-14-6335-2021.

M. Zanatta *et al.*, “A European aerosol phenomenology-5: Climatology of black carbon optical properties at 9 regional background sites across Europe,” *Atmos Environ*, vol. 145, pp. 346–364, 2016, doi: 10.1016/j.atmosenv.2016.09.035.

Integrating nephelometer

T. Müller, M. Laborde, G. Kassell, and A. Wiedensohler, “Design and performance of a three-wavelength LED-based total scatter and backscatter integrating nephelometer,” *Atmos Meas Tech*, vol. 4, no. 6, pp. 1291–1303, 2011, doi: 10.5194/amt-4-1291-2011.

Leak check Nephelometer (Aurora)

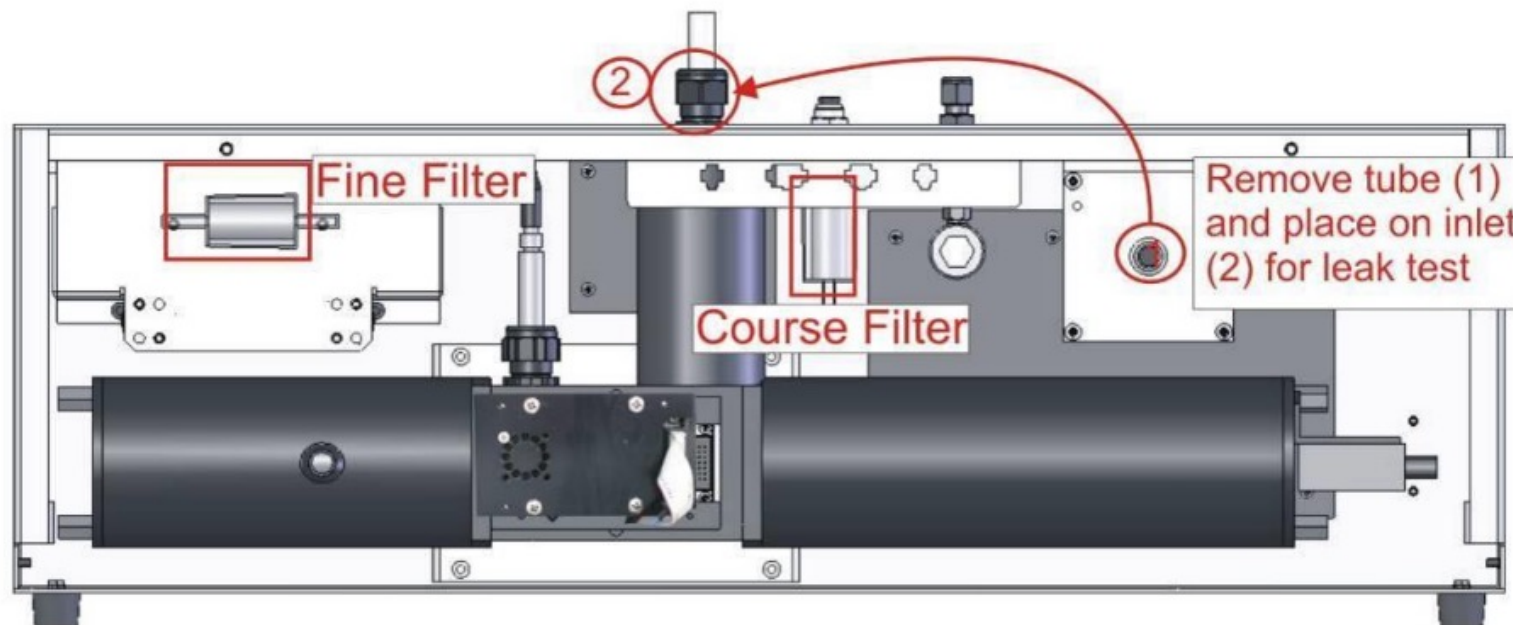

When needed:

- If a high zero reading is observed
- After any maintenance

Cell cleaning Nephelometer (Aurora)

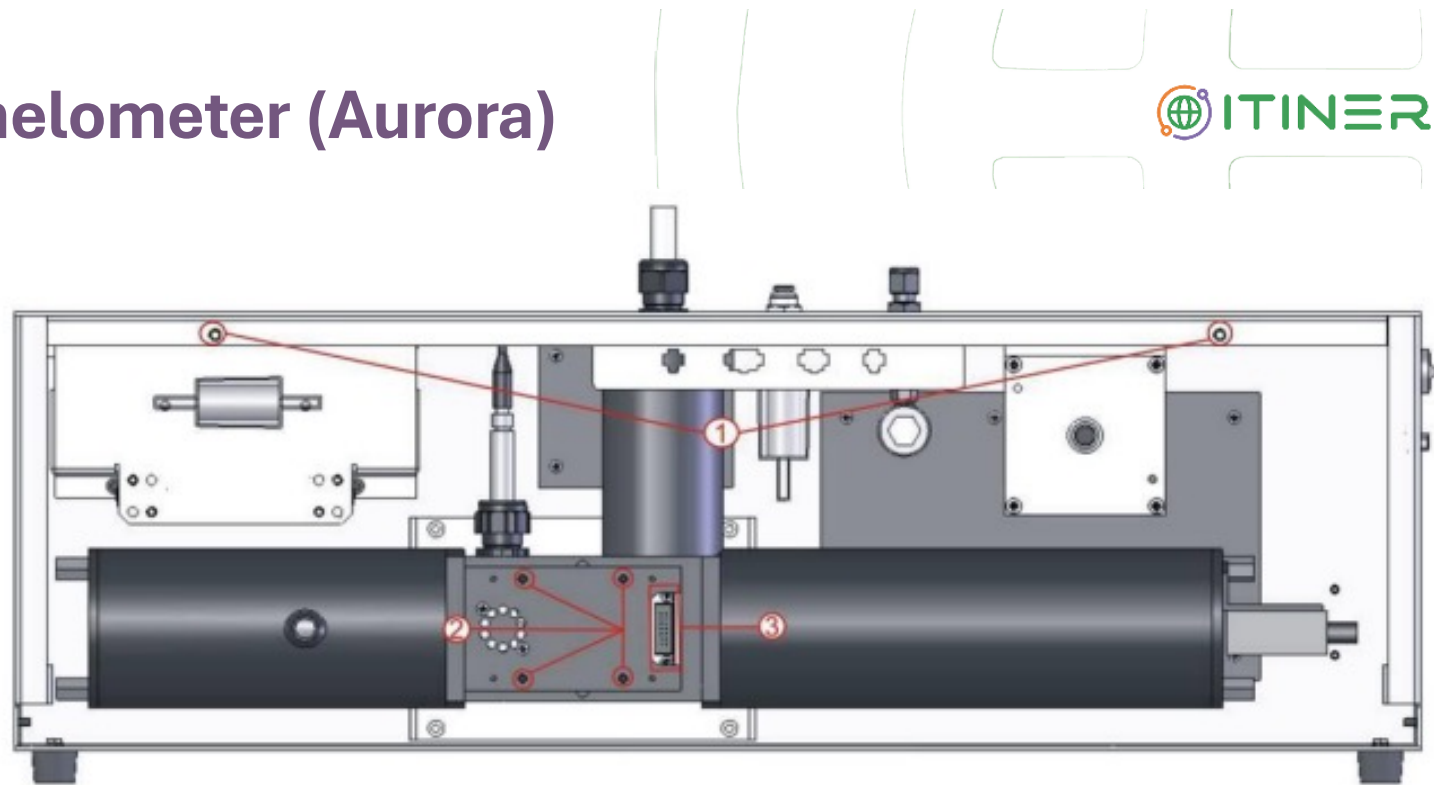

When needed:

- Every 6 months
- When the wall signal increases 5% above the initial value

Cell cleaning Aethalometer (AE33)

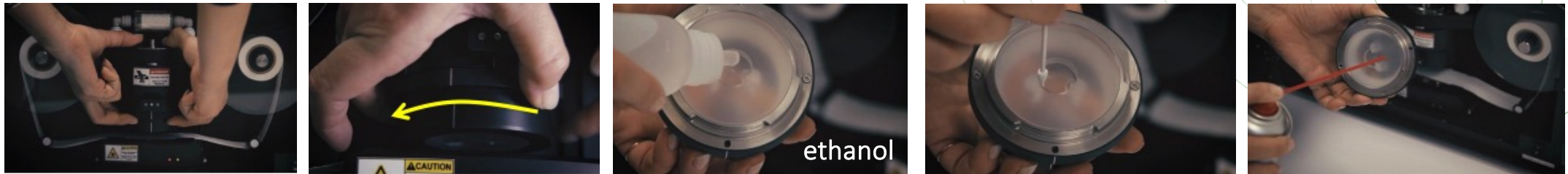

When needed:

- Every 6 months
- When the wall signal increases 5% above the initial value

Leak check Nephelometer (Aurora)



When needed:

- Every 6 months